



MC7800 Series

THREE-TERMINAL POSITIVE VOLTAGE REGULATORS

These voltage regulators are monolithic integrated circuits designed as fixed-voltage regulators for a wide variety of applications including local, on-card regulation. These regulators employ internal current limiting, thermal shutdown, and safe-area compensation. With adequate heatsinking they can deliver output currents in excess of 1.0 ampere. Although designed primarily as a fixed voltage regulator, these devices can be used with external components to obtain adjustable voltages and currents.

- Output Current in Excess of 1.0 Ampere
- No External Components Required
- Internal Thermal Overload Protection
- Internal Short-Circuit Current Limiting
- Output Transistor Safe-Area Compensation
- Output Voltage Offered in 2% and 4% Tolerance

THREE-TERMINAL POSITIVE FIXED VOLTAGE REGULATORS SILICON MONOLITHIC INTEGRATED CIRCUITS

K SUFFIX
METAL PACKAGE
CASE 1-03

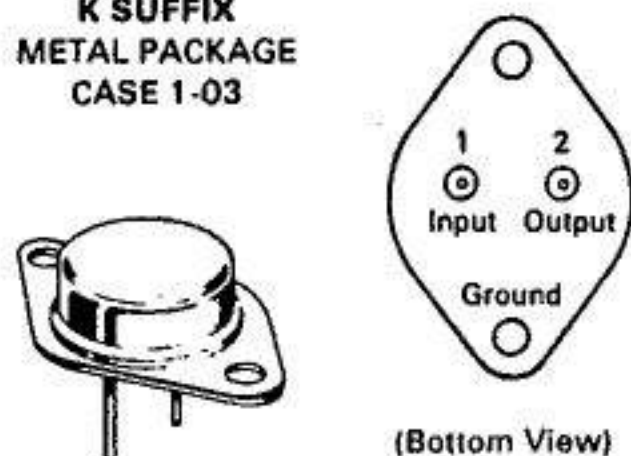

(Bottom View)
Pins 1 and 2 electrically isolated from case. Case is third electrical connection.

T SUFFIX
PLASTIC PACKAGE
CASE 221A-04

PIN 1. INPUT
2. GROUND
3. OUTPUT

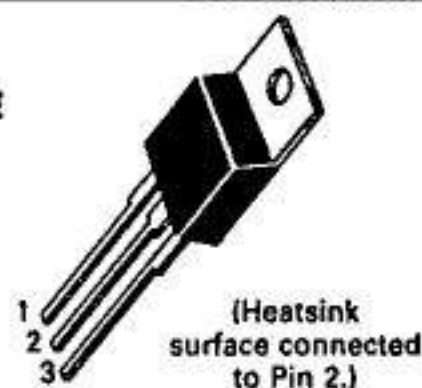

(Heatsink surface connected to Pin 2.)

REPRESENTATIVE SCHEMATIC DIAGRAM

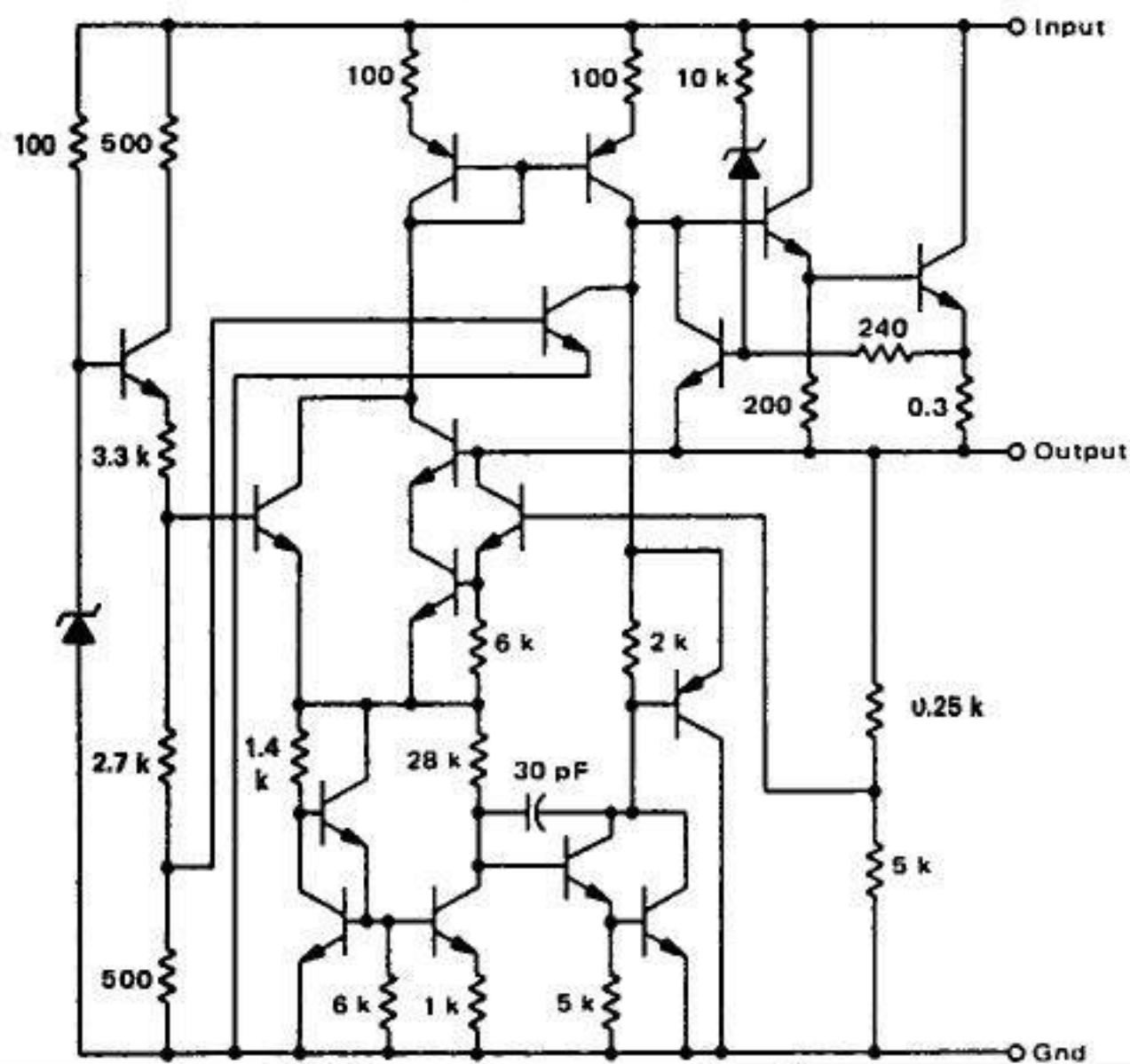

STANDARD APPLICATION

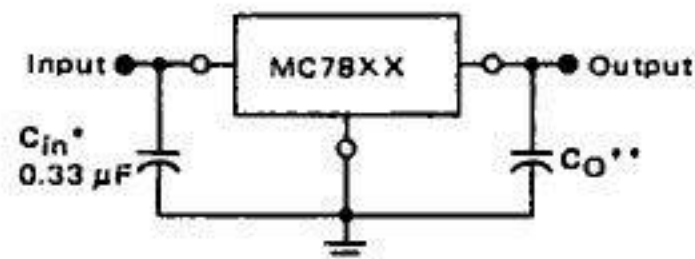

A common ground is required between the input and the output voltages. The input voltage must remain typically 2.0 V above the output voltage even during the low point on the input ripple voltage.

XX = these two digits of the type number indicate voltage.

* = C_{in} is required if regulator is located an appreciable distance from power supply filter.

** = C_o is not needed for stability; however, it does improve transient response.

XX indicates nominal voltage

ORDERING INFORMATION

Device	Output Voltage Tolerance	Tested Operating Junction Temp. Range	Package
MC78XXK MC78XXAK*	4% 2%	-55 to +150°C	Metal Power
MC78XXCK MC78XXACK*	4% 2%	0 to +125°C	
MC78XXCT MC78XXACT	4% 2%	-40 to +125°C	Plastic Power
MC78XXBT	4%		

*2% regulators in Metal Power packages are available in 5, 12 and 15 volt devices.

TYPE NO./VOLTAGE

MC7805	5.0 Volts	MC7812	12 Volts
MC7806	6.0 Volts	MC7815	15 Volts
MC7808	8.0 Volts	MC7818	18 Volts
MC7809	9.0 Volts	MC7824	24 Volts

MC7800 Series

MAXIMUM RATINGS ($T_A = +25^\circ\text{C}$ unless otherwise noted.)

Rating	Symbol	Value	Unit
Input Voltage (5.0 V – 18 V) (24 V)	V_{in}	35 40	Vdc
Power Dissipation and Thermal Characteristics			
Plastic Package			
$T_A = +25^\circ\text{C}$	P_D	Internally Limited	Watts
Derate above $T_A = +25^\circ\text{C}$	$1/\theta_{JA}$	15.4	mW/°C
Thermal Resistance, Junction to Air	θ_{JA}	65	°C/W
$T_C = +25^\circ\text{C}$	P_D	Internally Limited	Watts
Derate above $T_C = +75^\circ\text{C}$ (See Figure 1)	$1/\theta_{JC}$	200	mW/°C
Thermal Resistance, Junction to Case	θ_{JC}	5.0	°C/W
Metal Package			
$T_A = +25^\circ\text{C}$	P_D	Internally Limited	Watts
Derate above $T_A = +25^\circ\text{C}$	$1/\theta_{JA}$	22.5	mW/°C
Thermal Resistance, Junction to Air	θ_{JA}	45	°C/W
$T_C = +25^\circ\text{C}$	P_D	Internally Limited	Watts
Derate above $T_C = +65^\circ\text{C}$ (See Figure 2)	$1/\theta_{JC}$	182	mW/°C
Thermal Resistance, Junction to Case	θ_{JC}	5.5	°C/W
Storage Junction Temperature Range	T_{stg}	-65 to +150	°C
Operating Junction Temperature Range	T_J		°C
		-55 to +150	
		0 to +150	
		-40 to +150	

DEFINITIONS

Line Regulation — The change in output voltage for a change in the input voltage. The measurement is made under conditions of low dissipation or by using pulse techniques such that the average chip temperature is not significantly affected.

Load Regulation — The change in output voltage for a change in load current at constant chip temperature.

Maximum Power Dissipation — The maximum total device dissipation for which the regulator will operate within specifications.

Quiescent Current — That part of the input current that is not delivered to the load.

Output Noise Voltage — The rms ac voltage at the output, with constant load and no input ripple, measured over a specified frequency range.

Long Term Stability — Output voltage stability under accelerated life test conditions with the maximum rated voltage listed in the devices' electrical characteristics and maximum power dissipation.

MC7800 Series

MC7805, B, C

ELECTRICAL CHARACTERISTICS ($V_{in} = 10\text{ V}$, $I_O = 500\text{ mA}$, $T_J = T_{low}$ to T_{high} [Note 1] unless otherwise noted).

Characteristic	Symbol	MC7805			MC7805B			MC7805C			Unit
		Min	Typ	Max	Min	Typ	Max	Min	Typ	Max	
Output Voltage ($T_J = +25^\circ\text{C}$)	V_O	4.8	5.0	5.2	4.8	5.0	5.2	4.8	5.0	5.2	Vdc
Output Voltage ($5.0\text{ mA} \leq I_O \leq 1.0\text{ A}$, $P_O \leq 15\text{ W}$) $7.0\text{ Vdc} \leq V_{in} \leq 20\text{ Vdc}$ $8.0\text{ Vdc} \leq V_{in} \leq 20\text{ Vdc}$	V_O	—	—	—	—	—	—	4.75	5.0	5.25	Vdc
Line Regulation ($T_J = +25^\circ\text{C}$, Note 2) $7.0\text{ Vdc} \leq V_{in} \leq 25\text{ Vdc}$ $8.0\text{ Vdc} \leq V_{in} \leq 12\text{ Vdc}$	Reg _{line}	—	2.0	50	—	7.0	100	—	7.0	100	mV
Load Regulation ($T_J = +25^\circ\text{C}$, Note 2) $5.0\text{ mA} \leq I_O \leq 1.5\text{ A}$ $250\text{ mA} \leq I_O \leq 750\text{ mA}$	Reg _{load}	—	25	100	—	40	100	—	40	100	mV
Quiescent Current ($T_J = +25^\circ\text{C}$)	I_B	—	3.2	6.0	—	4.3	8.0	—	4.3	8.0	mA
Quiescent Current Change $7.0\text{ Vdc} \leq V_{in} \leq 25\text{ Vdc}$ $8.0\text{ Vdc} \leq V_{in} \leq 25\text{ Vdc}$ $5.0\text{ mA} \leq I_O \leq 1.0\text{ A}$	ΔI_B	—	—	—	—	—	—	—	—	1.3	mA
Ripple Rejection $8.0\text{ Vdc} \leq V_{in} \leq 18\text{ Vdc}$, $f = 120\text{ Hz}$	RR	68	75	—	—	68	—	—	68	—	dB
Dropout Voltage ($I_O = 1.0\text{ A}$, $T_J = +25^\circ\text{C}$)	$V_{in} - V_O$	—	2.0	2.5	—	2.0	—	—	2.0	—	Vdc
Output Noise Voltage ($T_A = +25^\circ\text{C}$) $10\text{ Hz} \leq f \leq 100\text{ kHz}$	V_n	—	10	40	—	10	—	—	10	—	$\mu\text{V}/V_O$
Output Resistance ($f = 1.0\text{ kHz}$)	r_O	—	17	—	—	17	—	—	17	—	m Ω
Short-Circuit Current Limit ($T_A = +25^\circ\text{C}$) $V_{in} = 35\text{ Vdc}$	I_{sc}	—	0.2	1.2	—	0.2	—	—	0.2	—	A
Peak Output Current ($T_J = +25^\circ\text{C}$)	I_{max}	1.3	2.5	3.3	—	2.2	—	—	2.2	—	A
Average Temperature Coefficient of Output Voltage	TCV_O	—	± 0.6	—	—	-1.1	—	—	-1.1	—	$\text{mV}/^\circ\text{C}$

MC7805A, AC

ELECTRICAL CHARACTERISTICS ($V_{in} = 10\text{ V}$, $I_O = 1.0\text{ A}$, $T_J = T_{low}$ to T_{high} [Note 1] unless otherwise noted).

Characteristics	Symbol	MC7805A			MC7805AC			Unit
		Min	Typ	Max	Min	Typ	Max	
Output Voltage ($T_J = +25^\circ\text{C}$)	V_O	4.9	5.0	5.1	4.9	5.0	5.1	Vdc
Output Voltage ($5.0\text{ mA} \leq I_O \leq 1.0\text{ A}$, $P_O \leq 15\text{ W}$) $7.5\text{ Vdc} \leq V_{in} \leq 20\text{ Vdc}$	V_O	4.8	5.0	5.2	4.8	5.0	5.2	Vdc
Line Regulation (Note 2) $7.5\text{ Vdc} \leq V_{in} \leq 25\text{ Vdc}$, $I_O = 500\text{ mA}$ $8.0\text{ Vdc} \leq V_{in} \leq 12\text{ Vdc}$ $8.0\text{ Vdc} \leq V_{in} \leq 12\text{ Vdc}$, $T_J = +25^\circ\text{C}$ $7.3\text{ Vdc} \leq V_{in} \leq 20\text{ Vdc}$, $T_J = +25^\circ\text{C}$	Reg _{line}	—	2.0	10	—	7.0	50	mV
Load Regulation (Note 2) $5.0\text{ mA} \leq I_O \leq 1.5\text{ A}$, $T_J = +25^\circ\text{C}$ $5.0\text{ mA} \leq I_O \leq 1.0\text{ A}$ $250\text{ mA} \leq I_O \leq 750\text{ mA}$, $T_J = +25^\circ\text{C}$ $250\text{ mA} \leq I_O \leq 750\text{ mA}$	Reg _{load}	—	2.0	25	—	25	100	mV
Quiescent Current $T_J = +25^\circ\text{C}$	I_B	—	—	5.0	—	—	6.0	mA
Quiescent Current Change $8.0\text{ Vdc} \leq V_{in} \leq 25\text{ Vdc}$, $I_O = 500\text{ mA}$ $7.5\text{ Vdc} \leq V_{in} \leq 20\text{ Vdc}$, $T_J = +25^\circ\text{C}$ $5.0\text{ mA} \leq I_O \leq 1.0\text{ A}$	ΔI_B	—	0.3	0.5	—	—	0.8	mA
Ripple Rejection $8.0\text{ Vdc} \leq V_{in} \leq 18\text{ Vdc}$, $f = 120\text{ Hz}$, $T_J = +25^\circ\text{C}$ $8.0\text{ Vdc} \leq V_{in} \leq 18\text{ Vdc}$, $f = 120\text{ Hz}$, $I_O = 500\text{ mA}$	RR	68	75	—	—	—	—	dB
Dropout Voltage ($I_O = 1.0\text{ A}$, $T_J = +25^\circ\text{C}$)	$V_{in} - V_O$	—	2.0	2.5	—	2.0	—	Vdc
Output Noise Voltage ($T_A = +25^\circ\text{C}$) $10\text{ Hz} \leq f \leq 100\text{ kHz}$	V_n	—	10	40	—	10	—	$\mu\text{V}/V_O$
Output Resistance ($f = 1.0\text{ kHz}$)	r_O	—	2.0	—	—	17	—	m Ω
Short-Circuit Current Limit ($T_A = +25^\circ\text{C}$) $V_{in} = 35\text{ Vdc}$	I_{sc}	—	0.2	1.2	—	0.2	—	A
Peak Output Current ($T_J = +25^\circ\text{C}$)	I_{max}	1.3	2.5	3.3	—	2.2	—	A
Average Temperature Coefficient of Output Voltage	TCV_O	—	± 0.6	—	—	-1.1	—	$\text{mV}/^\circ\text{C}$

NOTES: 1. $T_{low} = -55^\circ\text{C}$ for MC78XX, A
 $= 0^\circ$ for MC78XXC, AC
 $= -40^\circ\text{C}$ for MC78XXB
 $T_{high} = +150^\circ\text{C}$ for MC78XX, A
 $= +125^\circ\text{C}$ for MC78XXC, AC, B

2. Load and line regulation are specified at constant junction temperature. Changes in V_O due to heating effects must be taken into account separately. Pulse testing with low duty cycle is used.

MC7800 Series

MC7806, B, C

ELECTRICAL CHARACTERISTICS ($V_{in} = 11\text{ V}$, $I_O = 500\text{ mA}$, $T_J = T_{low}$ to T_{high} [Note 1] unless otherwise noted).

Characteristic	Symbol	MC7806			MC7806B			MC7806C			Unit
		Min	Typ	Max	Min	Typ	Max	Min	Typ	Max	
Output Voltage ($T_J = +25^\circ\text{C}$)	V_O	5.75	6.0	6.25	5.75	6.0	6.25	5.75	6.0	6.25	Vdc
Output Voltage ($5.0\text{ mA} \leq I_O \leq 1.0\text{ A}$, $P_O \leq 15\text{ W}$) $8.0\text{ Vdc} \leq V_{in} \leq 21\text{ Vdc}$ $9.0\text{ Vdc} \leq V_{in} \leq 21\text{ Vdc}$	V_O	—	—	—	—	—	—	5.7	6.0	6.3	Vdc
Line Regulation ($T_J = +25^\circ\text{C}$, Note 2) $8.0\text{ Vdc} \leq V_{in} \leq 25\text{ Vdc}$ $9.0\text{ Vdc} \leq V_{in} \leq 13\text{ Vdc}$	Regline	—	3.0	60	—	9.0	120	—	9.0	120	mV
Load Regulation ($T_J = +25^\circ\text{C}$, Note 2) $5.0\text{ mA} \leq I_O \leq 1.5\text{ A}$ $250\text{ mA} \leq I_O \leq 750\text{ mA}$	Regload	—	27	100	—	43	120	—	43	120	mV
Quiescent Current ($T_J = +25^\circ\text{C}$)	I_B	—	3.2	6.0	—	4.3	8.0	—	4.3	8.0	mA
Quiescent Current Change $8.0\text{ Vdc} \leq V_{in} \leq 25\text{ Vdc}$ $9.0\text{ Vdc} \leq V_{in} \leq 25\text{ Vdc}$ $5.0\text{ mA} \leq I_O \leq 1.0\text{ A}$	ΔI_B	—	—	—	—	—	—	—	—	1.3	mA
Ripple Rejection $9.0\text{ Vdc} \leq V_{in} \leq 19\text{ Vdc}$, $f = 120\text{ Hz}$	RR	65	73	—	—	65	—	—	65	—	dB
Dropout Voltage ($I_O = 1.0\text{ A}$, $T_J = +25^\circ\text{C}$)	$V_{in}-V_O$	—	2.0	2.5	—	2.0	—	—	2.0	—	Vdc
Output Noise Voltage ($T_A = +25^\circ\text{C}$) $10\text{ Hz} \leq f \leq 100\text{ kHz}$	V_n	—	10	40	—	10	—	—	10	—	$\mu\text{V}/V_O$
Output Resistance $f = 1.0\text{ kHz}$	r_O	—	17	—	—	17	—	—	17	—	$\text{m}\Omega$
Short-Circuit Current Limit ($T_A = +25^\circ\text{C}$) $V_{in} = 35\text{ Vdc}$	I_{sc}	—	0.2	1.2	—	0.2	—	—	0.2	—	A
Peak Output Current ($T_J = +25^\circ\text{C}$)	I_{max}	1.3	2.5	3.3	—	2.2	—	—	2.2	—	A
Average Temperature Coefficient of Output Voltage	TCV_O	—	± 0.7	—	—	-0.8	—	—	-0.8	—	$\text{mV}/^\circ\text{C}$

MC7806AC

ELECTRICAL CHARACTERISTICS ($V_{in} = 11\text{ V}$, $I_O = 1.0\text{ A}$, $T_J = T_{low}$ to T_{high} [Note 1] unless otherwise noted).

Characteristics	Symbol	MC7806AC			Unit
		Min	Typ	Max	
Output Voltage ($T_J = +25^\circ\text{C}$)	V_O	5.88	6.0	6.12	Vdc
Output Voltage ($5.0\text{ mA} \leq I_O \leq 1.0\text{ A}$, $P_O \leq 15\text{ W}$) $8.6\text{ Vdc} \leq V_{in} \leq 21\text{ Vdc}$	V_O	5.78	6.0	6.24	Vdc
Line Regulation (Note 2) $8.6\text{ Vdc} \leq V_{in} \leq 25\text{ Vdc}$, $I_O = 500\text{ mA}$ $9.0\text{ Vdc} \leq V_{in} \leq 13\text{ Vdc}$ $9.0\text{ Vdc} \leq V_{in} \leq 13\text{ Vdc}$, $T_J = +25^\circ\text{C}$ $8.3\text{ Vdc} \leq V_{in} \leq 21\text{ Vdc}$, $T_J = +25^\circ\text{C}$	Regline	—	9.0	60	mV
Load Regulation (Note 2) $5.0\text{ mA} \leq I_O \leq 1.5\text{ A}$, $T_J = +25^\circ\text{C}$ $5.0\text{ mA} \leq I_O \leq 1.0\text{ A}$ $250\text{ mA} \leq I_O \leq 750\text{ mA}$, $T_J = +25^\circ\text{C}$ $250\text{ mA} \leq I_O \leq 750\text{ mA}$	Regload	—	43	100	mV
Quiescent Current $T_J = +25^\circ\text{C}$	I_B	—	4.3	6.0	mA
Quiescent Current Change $9.0\text{ Vdc} \leq V_{in} \leq 25\text{ Vdc}$, $I_O = 500\text{ mA}$ $8.6\text{ Vdc} \leq V_{in} \leq 21\text{ Vdc}$, $T_J = +25^\circ\text{C}$ $5.0\text{ mA} \leq I_O \leq 1.0\text{ A}$	ΔI_B	—	—	0.8	mA
Ripple Rejection $9.0\text{ Vdc} \leq V_{in} \leq 19\text{ Vdc}$, $f = 120\text{ Hz}$, $T_J = +25^\circ\text{C}$ $9.0\text{ Vdc} \leq V_{in} \leq 19\text{ Vdc}$, $f = 120\text{ Hz}$, $I_O = 500\text{ mA}$	RR	—	65	—	dB
Dropout Voltage ($I_O = 1.0\text{ A}$, $T_J = +25^\circ\text{C}$)	$V_{in}-V_O$	—	2.0	—	Vdc
Output Noise Voltage ($T_A = +25^\circ\text{C}$) $10\text{ Hz} \leq f \leq 100\text{ kHz}$	V_n	—	10	—	$\mu\text{V}/V_O$
Output Resistance ($f = 1.0\text{ kHz}$)	r_O	—	17	—	$\text{m}\Omega$
Short-Circuit Current Limit ($T_A = +25^\circ\text{C}$) $V_{in} = 35\text{ Vdc}$	I_{sc}	—	0.2	—	A
Peak Output Current ($T_J = +25^\circ\text{C}$)	I_{max}	—	2.2	—	A
Average Temperature Coefficient of Output Voltage	TCV_O	—	-0.8	—	$\text{mV}/^\circ\text{C}$

NOTES: 1. $T_{low} = -55^\circ\text{C}$ for MC78XX
 $= 0^\circ$ for MC78XXC, AC
 $= -40^\circ\text{C}$ for MC78XXB
 $T_{high} = +150^\circ\text{C}$ for MC78XX
 $= +125^\circ\text{C}$ for MC78XXC, AC, B

2. Load and line regulation are specified at constant junction temperature. Changes in V_O due to heating effects must be taken into account separately. Pulse testing with low duty cycle is used.

MC7800 Series

MC7808, B, C

ELECTRICAL CHARACTERISTICS ($V_{in} = 14\text{ V}$, $I_O = 500\text{ mA}$, $T_J = T_{low}$ to T_{high} [Note 1] unless otherwise noted).

Characteristic	Symbol	MC7808			MC7808B			MC7808C			Unit
		Min	Typ	Max	Min	Typ	Max	Min	Typ	Max	
Output Voltage ($T_J = +25^\circ\text{C}$)	V_O	7.7	8.0	8.3	7.7	8.0	8.3	7.7	8.0	8.3	Vdc
Output Voltage ($5.0\text{ mA} \leq I_O \leq 1.0\text{ A}$, $P_O \leq 15\text{ W}$) $10.5\text{ Vdc} \leq V_{in} \leq 23\text{ Vdc}$ $11.5\text{ Vdc} \leq V_{in} \leq 23\text{ Vdc}$	V_O	—	—	—	—	—	—	7.6	8.0	8.4	Vdc
Line Regulation ($T_J = +25^\circ\text{C}$, Note 2) $10.5\text{ Vdc} \leq V_{in} \leq 25\text{ Vdc}$ $11\text{ Vdc} \leq V_{in} \leq 17\text{ Vdc}$	Regline	—	3.0	80	—	12	160	—	12	160	mV
Load Regulation ($T_J = +25^\circ\text{C}$, Note 2) $5.0\text{ mA} \leq I_O \leq 1.5\text{ A}$ $250\text{ mA} \leq I_O \leq 750\text{ mA}$	Regload	—	28	100	—	45	160	—	45	160	mV
Quiescent Current ($T_J = +25^\circ\text{C}$)	I_B	—	3.2	6.0	—	4.3	8.0	—	4.3	8.0	mA
Quiescent Current Change $10.5\text{ Vdc} \leq V_{in} \leq 25\text{ Vdc}$ $11.5\text{ Vdc} \leq V_{in} \leq 25\text{ Vdc}$ $5.0\text{ mA} \leq I_O \leq 1.0\text{ A}$	ΔI_B	—	—	—	—	—	—	—	—	1.0	mA
Ripple Rejection $11.5\text{ Vdc} \leq V_{in} \leq 21.5\text{ Vdc}$, $f = 120\text{ Hz}$	RR	62	70	—	—	62	—	—	62	—	dB
Dropout Voltage ($I_O = 1.0\text{ A}$, $T_J = +25^\circ\text{C}$)	$V_{in}-V_O$	—	2.0	2.5	—	2.0	—	—	2.0	—	Vdc
Output Noise Voltage ($T_A = +25^\circ\text{C}$) $10\text{ Hz} \leq f \leq 100\text{ kHz}$	V_n	—	10	40	—	10	—	—	10	—	$\mu\text{V}/V_O$
Output Resistance $f = 1.0\text{ kHz}$	r_O	—	18	—	—	18	—	—	18	—	$\text{m}\Omega$
Short-Circuit Current Limit ($T_A = +25^\circ\text{C}$) $V_{in} = 35\text{ Vdc}$	I_{sc}	—	0.2	1.2	—	0.2	—	—	0.2	—	A
Peak Output Current ($T_J = +25^\circ\text{C}$)	I_{max}	1.3	2.5	3.3	—	2.2	—	—	2.2	—	A
Average Temperature Coefficient of Output Voltage	TCV_O	—	± 1.0	—	—	-0.8	—	—	-0.8	—	$\text{mV}/^\circ\text{C}$

MC7808AC

ELECTRICAL CHARACTERISTICS ($V_{in} = 14\text{ V}$, $I_O = 1.0\text{ A}$, $T_J = T_{low}$ to T_{high} [Note 1] unless otherwise noted).

Characteristics	Symbol	MC7808AC			Unit
		Min	Typ	Max	
Output Voltage ($T_J = +25^\circ\text{C}$)	V_O	7.84	8.0	8.16	Vdc
Output Voltage ($5.0\text{ mA} \leq I_O \leq 1.0\text{ A}$, $P_O \leq 15\text{ W}$) $10.6\text{ Vdc} \leq V_{in} \leq 23\text{ Vdc}$	V_O	7.7	8.0	8.3	Vdc
Line Regulation (Note 2) $10.6\text{ Vdc} \leq V_{in} \leq 25\text{ Vdc}$, $I_O = 500\text{ mA}$ $11\text{ Vdc} \leq V_{in} \leq 17\text{ Vdc}$ $11\text{ Vdc} \leq V_{in} \leq 17\text{ Vdc}$, $T_J = +25^\circ\text{C}$ $10.4\text{ Vdc} \leq V_{in} \leq 23\text{ Vdc}$, $T_J = +25^\circ\text{C}$	Regline	—	12	80	mV
Load Regulation (Note 2) $5.0\text{ mA} \leq I_O \leq 1.5\text{ A}$, $T_J = +25^\circ\text{C}$ $5.0\text{ mA} \leq I_O \leq 1.0\text{ A}$ $250\text{ mA} \leq I_O \leq 750\text{ mA}$, $T_J = +25^\circ\text{C}$ $250\text{ mA} \leq I_O \leq 750\text{ mA}$	Regload	—	45	100	mV
Quiescent Current $T_J = +25^\circ\text{C}$	I_B	—	—	6.0	mA
Quiescent Current Change $11\text{ Vdc} \leq V_{in} \leq 25\text{ Vdc}$, $I_O = 500\text{ mA}$ $10.6\text{ Vdc} \leq V_{in} \leq 23\text{ Vdc}$, $T_J = +25^\circ\text{C}$ $5.0\text{ mA} \leq I_O \leq 1.0\text{ A}$	ΔI_B	—	—	0.8	mA
Ripple Rejection $11.5\text{ Vdc} \leq V_{in} \leq 21.5\text{ Vdc}$, $f = 120\text{ Hz}$, $T_J = +25^\circ\text{C}$ $11.5\text{ Vdc} \leq V_{in} \leq 21.5\text{ Vdc}$, $f = 120\text{ Hz}$, $I_O = 500\text{ mA}$	RR	—	—	—	dB
Dropout Voltage ($I_O = 1.0\text{ A}$, $T_J = +25^\circ\text{C}$)	$V_{in}-V_O$	—	2.0	—	Vdc
Output Noise Voltage ($T_A = +25^\circ\text{C}$) $10\text{ Hz} \leq f \leq 100\text{ kHz}$	V_n	—	10	—	$\mu\text{V}/V_O$
Output Resistance ($f = 1.0\text{ kHz}$)	r_O	—	18	—	$\text{m}\Omega$
Short-Circuit Current Limit ($T_A = +25^\circ\text{C}$) $V_{in} = 35\text{ Vdc}$	I_{sc}	—	0.2	—	A
Peak Output Current ($T_J = +25^\circ\text{C}$)	I_{max}	—	2.2	—	A
Average Temperature Coefficient of Output Voltage	TCV_O	—	-0.8	—	$\text{mV}/^\circ\text{C}$

NOTES: 1. $T_{low} = -55^\circ\text{C}$ for MC78XX
 $= 0^\circ$ for MC78XXC, AC
 $= -40^\circ\text{C}$ for MC78XXB
 $T_{high} = +150^\circ\text{C}$ for MC78XX
 $= +125^\circ\text{C}$ for MC78XXC, AC, B

2. Load and line regulation are specified at constant junction temperature. Changes in V_O due to heating effects must be taken into account separately. Pulse testing with low duty cycle is used.

MC7800 Series

MC7809CT

ELECTRICAL CHARACTERISTICS ($V_{in} = 15\text{ V}$, $I_O = 500\text{ mA}$, $T_J = 0^\circ\text{C}$ to $+125^\circ\text{C}$ unless otherwise noted).

Characteristic	Symbol	MC7809CT			Unit
		Min	Typ	Max	
Output Voltage ($T_J = +25^\circ\text{C}$)	V_O	8.65	9.0	9.35	Vdc
Output Voltage ($5.0\text{ mA} \leq I_O \leq 1.0\text{ A}$, $P_O \leq 15\text{ W}$) $11.5\text{ Vdc} \leq V_{in} \leq 24\text{ Vdc}$	V_O	8.55	9.0	9.45	Vdc
Line Regulation ($T_J = +25^\circ\text{C}$, Note 1) $11.5\text{ Vdc} \leq V_{in} \leq 26\text{ Vdc}$ $11.5\text{ Vdc} \leq V_{in} \leq 17\text{ Vdc}$	Regline	—	12 5.0	50 25	mV
Load Regulation ($T_J = +25^\circ\text{C}$, Note 1) $5.0\text{ mA} \leq I_O \leq 1.5\text{ A}$ $250\text{ mA} \leq I_O \leq 750\text{ mA}$	Regload	—	35 12	50 25	mV
Quiescent Current ($T_J = +25^\circ\text{C}$)	I_B	—	4.3	8.0	mA
Quiescent Current Change $11.5\text{ Vdc} \leq V_{in} \leq 26\text{ Vdc}$ $5.0\text{ mA} \leq I_O \leq 1.0\text{ A}$	ΔI_B	—	—	1.0 0.5	mA
Ripple Rejection $11.5\text{ Vdc} \leq V_{in} \leq 21.5\text{ Vdc}$, $f = 120\text{ Hz}$	RR	—	61	—	dB
Dropout Voltage ($I_O = 1.0\text{ A}$, $T_J = +25^\circ\text{C}$)	$V_{in} - V_O$	—	2.0	—	Vdc
Output Noise Voltage ($T_A = +25^\circ\text{C}$) $10\text{ Hz} \leq f \leq 100\text{ kHz}$	V_n	—	10	—	$\mu\text{V}/V_O$
Output Resistance $f = 1.0\text{ kHz}$	r_O	—	18	—	$\text{m}\Omega$
Short-Circuit Current Limit ($T_A = +25^\circ\text{C}$) $V_{in} = 35\text{ Vdc}$	I_{sc}	—	0.2	—	A
Peak Output Current ($T_J = +25^\circ\text{C}$)	I_{max}	—	2.2	—	A
Average Temperature Coefficient of Output Voltage	TCV_O	—	-1.0	—	$\text{mV}/^\circ\text{C}$

NOTE 1: Load and line regulation are specified at constant junction temperature. Changes in V_O due to heating effects must be taken into account separately. Pulse testing with low duty cycle is used.

MC7800 Series

MC7812, B, C

ELECTRICAL CHARACTERISTICS ($V_{in} = 19\text{ V}$, $I_O = 500\text{ mA}$, $T_J = T_{low}$ to T_{high} [Note 1] unless otherwise noted).

Characteristic	Symbol	MC7812			MC7812B			MC7812C			Unit
		Min	Typ	Max	Min	Typ	Max	Min	Typ	Max	
Output Voltage ($T_J = +25^\circ\text{C}$)	V_O	11.5	12	12.5	11.5	12	12.5	11.5	12	12.5	Vdc
Output Voltage ($5.0\text{ mA} \leq I_O \leq 1.0\text{ A}$, $P_O \leq 15\text{ W}$) $14.5\text{ Vdc} \leq V_{in} \leq 27\text{ Vdc}$ $15.5\text{ Vdc} \leq V_{in} \leq 27\text{ Vdc}$	V_O	— 11.4	— 12	— 12.6	— 11.4	— 12	— 12.6	11.4 —	12 —	12.6 —	Vdc
Line Regulation ($T_J = +25^\circ\text{C}$, Note 2) $14.5\text{ Vdc} \leq V_{in} \leq 30\text{ Vdc}$ $16\text{ Vdc} \leq V_{in} \leq 22\text{ Vdc}$	Reg _{line}	— —	5.0 3.0	120 60	— —	13 6.0	240 120	— —	13 6.0	240 120	mV
Load Regulation ($T_J = +25^\circ\text{C}$, Note 2) $5.0\text{ mA} \leq I_O \leq 1.5\text{ A}$ $250\text{ mA} \leq I_O \leq 750\text{ mA}$	Reg _{load}	— —	30 10	120 60	— —	46 17	240 120	— —	46 17	240 120	mV
Quiescent Current ($T_J = +25^\circ\text{C}$)	I_B	—	3.4	6.0	—	4.4	8.0	—	4.4	8.0	mA
Quiescent Current Change $14.5\text{ Vdc} \leq V_{in} \leq 30\text{ Vdc}$ $15\text{ Vdc} \leq V_{in} \leq 30\text{ Vdc}$ $5.0\text{ mA} \leq I_O \leq 1.0\text{ A}$	ΔI_B	— — —	— 0.3 0.04	— 0.8 0.5	— — —	— — —	— 1.0 0.5	— — —	— — —	1.0 — 0.5	mA
Ripple Rejection $15\text{ Vdc} \leq V_{in} \leq 25\text{ Vdc}$, $f = 120\text{ Hz}$	RR	61	68	—	—	60	—	—	60	—	dB
Dropout Voltage ($I_O = 1.0\text{ A}$, $T_J = +25^\circ\text{C}$)	$V_{in} - V_O$	—	2.0	2.5	—	2.0	—	—	2.0	—	Vdc
Output Noise Voltage ($T_A = +25^\circ\text{C}$) $10\text{ Hz} \leq f \leq 100\text{ kHz}$	V_n	—	10	40	—	10	—	—	10	—	$\mu\text{V}/V_O$
Output Resistance $f = 1.0\text{ kHz}$	r_O	—	18	—	—	18	—	—	18	—	m Ω
Short-Circuit Current Limit ($T_A = +25^\circ\text{C}$) $V_{in} = 35\text{ Vdc}$	I_{sc}	—	0.2	1.2	—	0.2	—	—	0.2	—	A
Peak Output Current ($T_J = +25^\circ\text{C}$)	I_{max}	1.3	2.5	3.3	—	2.2	—	—	2.2	—	A
Average Temperature Coefficient of Output Voltage	TCV_O	—	± 1.5	—	—	-1.0	—	—	-1.0	—	$\text{mV}/^\circ\text{C}$

MC7812A, AC

ELECTRICAL CHARACTERISTICS ($V_{in} = 19\text{ V}$, $I_O = 1.0\text{ A}$, $T_J = T_{low}$ to T_{high} [Note 1] unless otherwise noted)

Characteristics	Symbol	MC7812A			MC7812AC			Unit
		Min	Typ	Max	Min	Typ	Max	
Output Voltage ($T_J = +25^\circ\text{C}$)	V_O	11.75	12	12.25	11.75	12	12.25	Vdc
Output Voltage ($5.0\text{ mA} \leq I_O \leq 1.0\text{ A}$, $P_O \leq 15\text{ W}$) $14.8\text{ Vdc} \leq V_{in} \leq 27\text{ Vdc}$	V_O	11.5	12	12.5	11.5	12	12.5	Vdc
Line Regulation (Note 2) $14.8\text{ Vdc} \leq V_{in} \leq 30\text{ Vdc}$, $I_O = 500\text{ mA}$ $16\text{ Vdc} \leq V_{in} \leq 22\text{ Vdc}$ $16\text{ Vdc} \leq V_{in} \leq 22\text{ Vdc}$, $T_J = +25^\circ\text{C}$ $14.5\text{ Vdc} \leq V_{in} \leq 27\text{ Vdc}$, $T_J = +25^\circ\text{C}$	Reg _{line}	— — — —	5.0 8.0 3.0 5.0	18 30 9.0 18	— — — —	13 16 6.0 13	120 120 60 120	mV
Load Regulation (Note 2) $5.0\text{ mA} \leq I_O \leq 1.5\text{ A}$, $T_J = +25^\circ\text{C}$ $5.0\text{ mA} \leq I_O \leq 1.0\text{ A}$ $250\text{ mA} \leq I_O \leq 750\text{ mA}$, $T_J = +25^\circ\text{C}$ $250\text{ mA} \leq I_O \leq 750\text{ mA}$	Reg _{load}	— — — —	2.0 2.0 1.0 1.0	25 25 15 25	— — — —	46 46 17 17	100 100 — 50	mV
Quiescent Current $T_J = +25^\circ\text{C}$	I_B	— —	— 3.4	5.0 4.0	— —	— 4.4	6.0 6.0	mA
Quiescent Current Change $15\text{ Vdc} \leq V_{in} \leq 30\text{ Vdc}$, $I_O = 500\text{ mA}$ $14.8\text{ Vdc} \leq V_{in} \leq 27\text{ Vdc}$, $T_J = +25^\circ\text{C}$ $5.0\text{ mA} \leq I_O \leq 1.0\text{ A}$	ΔI_B	— — —	0.3 0.2 0.04	0.5 0.5 0.2	— — —	— — —	0.8 0.8 0.5	mA
Ripple Rejection $15\text{ Vdc} \leq V_{in} \leq 25\text{ Vdc}$, $f = 120\text{ Hz}$, $T_J = +25^\circ\text{C}$ $15\text{ Vdc} \leq V_{in} \leq 25\text{ Vdc}$, $f = 120\text{ Hz}$, $I_O = 500\text{ mA}$	RR	61 61	68 68	— —	— —	— 60	— —	dB
Dropout Voltage ($I_O = 1.0\text{ A}$, $T_J = +25^\circ\text{C}$)	$V_{in} - V_O$	—	2.0	2.5	—	2.0	—	Vdc
Output Noise Voltage ($T_A = +25^\circ\text{C}$) $10\text{ Hz} \leq f \leq 100\text{ kHz}$	V_n	—	10	40	—	10	—	$\mu\text{V}/V_O$
Output Resistance ($f = 1.0\text{ kHz}$)	r_O	—	2.0	—	—	18	—	m Ω
Short-Circuit Current Limit ($T_A = +25^\circ\text{C}$) $V_{in} = 35\text{ Vdc}$	I_{sc}	—	0.2	1.2	—	0.2	—	A
Peak Output Current ($T_J = +25^\circ\text{C}$)	I_{max}	1.3	2.5	3.3	—	2.2	—	A
Average Temperature Coefficient of Output Voltage	TCV_O	—	± 1.5	—	—	-1.0	—	$\text{mV}/^\circ\text{C}$

NOTES: 1. $T_{low} = -55^\circ\text{C}$ for MC78XX, A
 $= 0^\circ\text{C}$ for MC78XXC, AC
 $= -40^\circ\text{C}$ for MC78XXB
 $T_{high} = +150^\circ\text{C}$ for MC78XX, A
 $= +125^\circ\text{C}$ for MC78XXC, AC, B

2. Load and line regulation are specified at constant junction temperature. Changes in V_O due to heating effects must be taken into account separately. Pulse testing with low duty cycle is used.

MC7800 Series

MC7815, B, C

ELECTRICAL CHARACTERISTICS ($V_{in} = 23\text{ V}$, $I_O = 500\text{ mA}$, $T_J = T_{low}$ to T_{high} [Note 1] unless otherwise noted).

Characteristic	Symbol	MC7815			MC7815B			MC7815C			Unit
		Min	Typ	Max	Min	Typ	Max	Min	Typ	Max	
Output Voltage ($T_J = +25^\circ\text{C}$)	V_O	14.4	15	15.6	14.4	15	15.6	14.4	15	15.6	Vdc
Output Voltage ($5.0\text{ mA} \leq I_O \leq 1.0\text{ A}$, $P_O \leq 15\text{ W}$) $17.5\text{ Vdc} \leq V_{in} \leq 30\text{ Vdc}$ $18.5\text{ Vdc} \leq V_{in} \leq 30\text{ Vdc}$	V_O	—	—	—	—	—	—	14.25	15	16.75	Vdc
Line Regulation ($T_J = +25^\circ\text{C}$, Note 2) $17.5\text{ Vdc} \leq V_{in} \leq 30\text{ Vdc}$ $20\text{ Vdc} \leq V_{in} \leq 26\text{ Vdc}$	Reg _{line}	—	8.0	150	—	13	300	—	13	300	mV
Load Regulation ($T_J = +25^\circ\text{C}$, Note 2) $5.0\text{ mA} \leq I_O \leq 1.5\text{ A}$ $250\text{ mA} \leq I_O \leq 750\text{ mA}$	Reg _{load}	—	32	150	—	62	300	—	52	300	mV
Quiescent Current ($T_J = +25^\circ\text{C}$)	I_B	—	3.4	6.0	—	4.4	8.0	—	4.4	8.0	mA
Quiescent Current Change $17.5\text{ Vdc} \leq V_{in} \leq 30\text{ Vdc}$ $18.5\text{ Vdc} \leq V_{in} \leq 30\text{ Vdc}$ $5.0\text{ mA} \leq I_O \leq 1.0\text{ A}$	ΔI_B	—	—	—	—	—	—	—	—	1.0	mA
Ripple Rejection $18.5\text{ Vdc} \leq V_{in} \leq 28.5\text{ Vdc}$, $f = 120\text{ Hz}$	RR	60	66	—	—	58	—	—	58	—	dB
Dropout Voltage ($I_O = 1.0\text{ A}$, $T_J = +25^\circ\text{C}$)	$V_{in} - V_O$	—	2.0	2.5	—	2.0	—	—	2.0	—	Vdc
Output Noise Voltage ($T_A = +25^\circ\text{C}$) $10\text{ Hz} \leq f \leq 100\text{ kHz}$	V_n	—	10	40	—	10	—	—	10	—	$\mu\text{V}/V_O$
Output Resistance $f = 1.0\text{ kHz}$	r_O	—	19	—	—	19	—	—	19	—	m Ω
Short-Circuit Current Limit ($T_A = +25^\circ\text{C}$) $V_{in} = 35\text{ Vdc}$	I_{sc}	—	0.2	1.2	—	0.2	—	—	0.2	—	A
Peak Output Current ($T_J = +25^\circ\text{C}$)	I_{max}	1.3	2.5	3.3	—	2.2	—	—	2.2	—	A
Average Temperature Coefficient of Output Voltage	TCV _O	—	± 1.8	—	—	-1.0	—	—	-1.0	—	mV/ $^\circ\text{C}$

MC7815A, AC

ELECTRICAL CHARACTERISTICS ($V_{in} = 23\text{ V}$, $I_O = 1.0\text{ A}$, $T_J = T_{low}$ to T_{high} [Note 1] unless otherwise noted)

Characteristic	Symbol	MC7815A			MG7815AC			Unit
		Min	Typ	Max	Min	Typ	Max	
Output Voltage ($T_J = +25^\circ\text{C}$)	V_O	14.7	15	15.3	14.7	15	15.3	Vdc
Output Voltage ($5.0\text{ mA} \leq I_O \leq 1.0\text{ A}$, $P_O \leq 15\text{ W}$) $17.9\text{ Vdc} \leq V_{in} \leq 30\text{ Vdc}$	V_O	14.4	15	15.6	14.4	15	15.6	Vdc
Line Regulation (Note 2) $17.9\text{ Vdc} \leq V_{in} \leq 30\text{ Vdc}$, $I_O = 500\text{ mA}$ $20\text{ Vdc} \leq V_{in} \leq 26\text{ Vdc}$ $20\text{ Vdc} \leq V_{in} \leq 26\text{ Vdc}$, $T_J = +25^\circ\text{C}$ $17.5\text{ Vdc} \leq V_{in} \leq 30\text{ Vdc}$, $T_J = +25^\circ\text{C}$	Reg _{line}	—	6.0	22	—	13	150	mV
Load Regulation (Note 2) $5.0\text{ mA} \leq I_O \leq 1.5\text{ A}$, $T_J = +25^\circ\text{C}$ $5.0\text{ mA} \leq I_O \leq 1.0\text{ A}$ $250\text{ mA} \leq I_O \leq 750\text{ mA}$, $T_J = +25^\circ\text{C}$ $250\text{ mA} \leq I_O \leq 750\text{ mA}$	Reg _{load}	—	2.0	25	—	52	100	mV
Quiescent Current $T_J = +25^\circ\text{C}$	I_B	—	—	5.5	—	—	6.0	mA
Quiescent Current Change $17.6\text{ Vdc} \leq V_{in} \leq 30\text{ Vdc}$, $I_O = 500\text{ mA}$ $17.5\text{ Vdc} \leq V_{in} \leq 30\text{ Vdc}$, $T_J = +25^\circ\text{C}$ $5.0\text{ mA} \leq I_O \leq 1.0\text{ A}$	ΔI_B	—	0.3	0.5	—	—	0.8	mA
Ripple Rejection $18.5\text{ Vdc} \leq V_{in} \leq 28.5\text{ Vdc}$, $f = 120\text{ Hz}$, $T_J = +25^\circ\text{C}$ $18.5\text{ Vdc} \leq V_{in} \leq 28.5\text{ Vdc}$, $f = 120\text{ Hz}$, $I_O = 500\text{ mA}$	RR	60	66	—	—	—	—	dB
Dropout Voltage ($I_O = 1.0\text{ A}$, $T_J = +25^\circ\text{C}$)	$V_{in} - V_O$	—	2.0	2.5	—	2.0	—	Vdc
Output Noise Voltage ($T_A = +25^\circ\text{C}$) $10\text{ Hz} \leq f \leq 100\text{ kHz}$	V_n	—	10	40	—	10	—	$\mu\text{V}/V_O$
Output Resistance ($f = 1.0\text{ kHz}$)	r_O	—	2.0	—	—	19	—	m Ω
Short-Circuit Current Limit ($T_A = +25^\circ\text{C}$) $V_{in} = 35\text{ Vdc}$	I_{sc}	—	0.2	1.2	—	0.2	—	A
Peak Output Current ($T_J = +25^\circ\text{C}$)	I_{max}	1.3	2.5	3.3	—	2.2	—	A
Average Temperature Coefficient of Output Voltage	TCV _O	—	± 1.8	—	—	-1.0	—	mV/ $^\circ\text{C}$

NOTES: 1. $T_{low} = -55^\circ\text{C}$ for MC78XX, A
 $= 0^\circ$ for MC78XXC, AC
 $= -40^\circ\text{C}$ for MC78XXB

$T_{high} = +150^\circ\text{C}$ for MC78XX, A
 $= +125^\circ\text{C}$ for MC78XXC, AC, B

2. Load and line regulation are specified at constant junction temperature. Changes in V_O due to heating effects must be taken into account separately. Pulse testing with low duty cycle is used.

MC7800 Series

MC7818, B, C

ELECTRICAL CHARACTERISTICS ($V_{in} = 27\text{ V}$, $I_O = 500\text{ mA}$, $T_J = T_{low}$ to T_{high} [Note 1] unless otherwise noted).

Characteristic	Symbol	MC7818			MC7818B			MC7818C			Unit
		Min	Typ	Max	Min	Typ	Max	Min	Typ	Max	
Output Voltage ($T_J = +25^\circ\text{C}$)	V_O	17.3	18	18.7	17.3	18	18.7	17.3	18	18.7	Vdc
Output Voltage ($5.0\text{ mA} \leq I_O \leq 1.0\text{ A}$, $P_O \leq 15\text{ W}$) $21\text{ Vdc} \leq V_{in} \leq 33\text{ Vdc}$ $22\text{ Vdc} \leq V_{in} \leq 33\text{ Vdc}$	V_O	— 17.1	— 18	— 18.9	— 17.1	— 18	— 18.9	— 17.1	— 18	— 18.9	Vdc
Line Regulation ($T_J = +25^\circ\text{C}$, Note 2) $21\text{ Vdc} \leq V_{in} \leq 33\text{ Vdc}$ $24\text{ Vdc} \leq V_{in} \leq 30\text{ Vdc}$	Regline	— —	7.0 4.0	180 90	— —	25 10	360 180	— —	25 10	360 180	mV
Load Regulation ($T_J = +25^\circ\text{C}$, Note 2) $5.0\text{ mA} \leq I_O \leq 1.5\text{ A}$ $250\text{ mA} \leq I_O \leq 750\text{ mA}$	Regload	— —	35 12	180 90	— —	55 22	360 180	— —	55 22	360 180	mV
Quiescent Current ($T_J = +25^\circ\text{C}$)	I_B	—	3.5	6.0	—	4.5	8.0	—	4.5	8.0	mA
Quiescent Current Change $21\text{ Vdc} \leq V_{in} \leq 33\text{ Vdc}$ $22\text{ Vdc} \leq V_{in} \leq 33\text{ Vdc}$ $5.0\text{ mA} \leq I_O \leq 1.0\text{ A}$	ΔI_B	— — —	— 0.3 0.04	— 0.8 0.5	— — —	— — —	— 1.0 0.5	— — —	— — —	1.0 — 0.5	mA
Ripple Rejection $22\text{ Vdc} \leq V_{in} \leq 33\text{ Vdc}$, $f = 120\text{ Hz}$	RR	59	65	—	—	57	—	—	57	—	dB
Dropout Voltage ($I_O = 1.0\text{ A}$, $T_J = +25^\circ\text{C}$)	$V_{in}-V_O$	—	2.0	2.5	—	2.0	—	—	2.0	—	Vdc
Output Noise Voltage ($T_A = +25^\circ\text{C}$) $10\text{ Hz} \leq f \leq 100\text{ kHz}$	V_n	—	10	40	—	10	—	—	10	—	$\mu\text{V}/V_O$
Output Resistance $f = 1.0\text{ kHz}$	r_O	—	19	—	—	19	—	—	19	—	m Ω
Short-Circuit Current Limit ($T_A = +25^\circ\text{C}$) $V_{in} = 35\text{ Vdc}$	I_{sc}	—	0.2	1.2	—	0.2	—	—	0.2	—	A
Peak Output Current ($T_J = +25^\circ\text{C}$)	I_{max}	1.3	2.5	3.3	—	2.2	—	—	2.2	—	A
Average Temperature Coefficient of Output Voltage	TCV_O	—	± 2.3	—	—	-1.0	—	—	-1.0	—	$\text{mV}/^\circ\text{C}$

MC7818AC

ELECTRICAL CHARACTERISTICS ($V_{in} = 27\text{ V}$, $I_O = 1.0\text{ A}$, $T_J = T_{low}$ to T_{high} [Note 1] unless otherwise noted).

Characteristics	Symbol	MC7818AC			Unit
		Min	Typ	Max	
Output Voltage ($T_J = +25^\circ\text{C}$)	V_O	17.64	18	18.36	Vdc
Output Voltage ($5.0\text{ mA} \leq I_O \leq 1.0\text{ A}$, $P_O \leq 15\text{ W}$) $21\text{ Vdc} \leq V_{in} \leq 33\text{ Vdc}$	V_O	17.3	18	18.7	Vdc
Line Regulation (Note 2) $21\text{ Vdc} \leq V_{in} \leq 33\text{ Vdc}$, $I_O = 500\text{ mA}$ $24\text{ Vdc} \leq V_{in} \leq 30\text{ Vdc}$ $24\text{ Vdc} \leq V_{in} \leq 30\text{ Vdc}$, $T_J = +25^\circ\text{C}$ $20.6\text{ Vdc} \leq V_{in} \leq 33\text{ Vdc}$, $T_J = +25^\circ\text{C}$	Regline	— — — —	25 28 10 25	180 180 90 180	mV
Load Regulation (Note 2) $5.0\text{ mA} \leq I_O \leq 1.5\text{ A}$, $T_J = +25^\circ\text{C}$ $5.0\text{ mA} \leq I_O \leq 1.0\text{ A}$ $250\text{ mA} \leq I_O \leq 750\text{ mA}$, $T_J = +25^\circ\text{C}$ $250\text{ mA} \leq I_O \leq 750\text{ mA}$	Regload	— — — —	55 55 — 22	100 100 — 50	mV
Quiescent Current $T_J = +25^\circ\text{C}$	I_B	— —	— 4.5	6.0 6.0	mA
Quiescent Current Change $21\text{ Vdc} \leq V_{in} \leq 33\text{ Vdc}$, $I_O = 500\text{ mA}$ $21\text{ Vdc} \leq V_{in} \leq 33\text{ Vdc}$, $T_J = +25^\circ\text{C}$ $5.0\text{ mA} \leq I_O \leq 1.0\text{ A}$	ΔI_B	— — —	— — —	0.8 0.8 0.5	mA
Ripple Rejection $22\text{ Vdc} \leq V_{in} \leq 32\text{ Vdc}$, $f = 120\text{ Hz}$, $T_J = +25^\circ\text{C}$ $22\text{ Vdc} \leq V_{in} \leq 32\text{ Vdc}$, $f = 120\text{ Hz}$, $I_O = 500\text{ mA}$	RR	— —	— 57	— —	dB
Dropout Voltage ($I_O = 1.0\text{ A}$, $T_J = +25^\circ\text{C}$)	$V_{in}-V_O$	—	2.0	—	Vdc
Output Noise Voltage ($T_A = +25^\circ\text{C}$) $10\text{ Hz} \leq f \leq 100\text{ kHz}$	V_n	—	10	—	$\mu\text{V}/V_O$
Output Resistance ($f = 1.0\text{ kHz}$)	r_O	—	19	—	m Ω
Short-Circuit Current Limit ($T_A = +25^\circ\text{C}$) $V_{in} = 35\text{ Vdc}$	I_{sc}	—	0.2	—	A
Peak Output Current ($T_J = +25^\circ\text{C}$)	I_{max}	—	2.2	—	A
Average Temperature Coefficient of Output Voltage	TCV_O	—	-1.0	—	$\text{mV}/^\circ\text{C}$

NOTES: 1. $T_{low} = -65^\circ\text{C}$ for MC78XX
 $= 0^\circ$ for MC78XXC, AC
 $= -40^\circ\text{C}$ for MC78XXB
 $T_{high} = +150^\circ\text{C}$ for MC78XX
 $= +125^\circ\text{C}$ for MC78XXC, AC, B

2. Load and line regulation are specified at constant junction temperature. Changes in V_O due to heating effects must be taken into account separately. Pulse testing with low duty cycle is used.

MC7800 Series

MC7824, B, C

ELECTRICAL CHARACTERISTICS ($V_{in} = 33\text{ V}$, $I_O = 500\text{ mA}$, $T_J = T_{low}$ to T_{high} [Note 1] unless otherwise noted).

Characteristic	Symbol	MC7824			MC7824B			MC7824C			Unit
		Min	Typ	Max	Min	Typ	Max	Min	Typ	Max	
Output Voltage ($T_J = +25^\circ\text{C}$)	V_O	23	24	25	23	24	25	23	24	25	Vdc
Output Voltage ($5.0\text{ mA} \leq I_O \leq 1.0\text{ A}$, $P_O \leq 15\text{ W}$) $27\text{ Vdc} \leq V_{in} \leq 38\text{ Vdc}$ $28\text{ Vdc} \leq V_{in} \leq 38\text{ Vdc}$	V_O	—	—	—	—	—	—	22.8	24	25.2	Vdc
Line Regulation ($T_J = +25^\circ\text{C}$, Note 2) $27\text{ Vdc} \leq V_{in} \leq 38\text{ Vdc}$ $30\text{ Vdc} \leq V_{in} \leq 38\text{ Vdc}$	Regline	—	10	240	—	31	480	—	31	480	mV
Load Regulation ($T_J = +25^\circ\text{C}$, Note 2) $5.0\text{ mA} \leq I_O \leq 1.5\text{ A}$ $250\text{ mA} \leq I_O \leq 750\text{ mA}$	Regload	—	40	240	—	60	480	—	60	480	mV
Quiescent Current ($T_J = +25^\circ\text{C}$)	I_B	—	3.6	6.0	—	4.6	8.0	—	4.6	8.0	mA
Quiescent Current Change $27\text{ Vdc} \leq V_{in} \leq 38\text{ Vdc}$ $28\text{ Vdc} \leq V_{in} \leq 38\text{ Vdc}$ $5.0\text{ mA} \leq I_O \leq 1.0\text{ A}$	ΔI_B	—	—	—	—	—	—	—	—	1.0	mA
Ripple Rejection $28\text{ Vdc} \leq V_{in} \leq 38\text{ Vdc}$, $f = 120\text{ Hz}$	RR	56	62	—	—	54	—	—	54	—	dB
Dropout Voltage ($I_O = 1.0\text{ A}$, $T_J = +25^\circ\text{C}$)	$V_{in} - V_O$	—	2.0	2.5	—	2.0	—	—	2.0	—	Vdc
Output Noise Voltage ($T_A = +25^\circ\text{C}$) $10\text{ Hz} \leq f \leq 100\text{ kHz}$	V_n	—	10	40	—	10	—	—	10	—	$\mu\text{V}/V_O$
Output Resistance $f = 1.0\text{ kHz}$	r_O	—	20	—	—	20	—	—	20	—	$\text{m}\Omega$
Short-Circuit Current Limit ($T_A = +25^\circ\text{C}$) $V_{in} = 35\text{ Vdc}$	I_{sc}	—	0.2	1.2	—	0.2	—	—	0.2	—	A
Peak Output Current ($T_J = +25^\circ\text{C}$)	I_{max}	1.3	2.5	3.3	—	2.2	—	—	2.2	—	A
Average Temperature Coefficient of Output Voltage	TCV_O	—	± 3.0	—	—	-1.5	—	—	-1.5	—	$\text{mV}/^\circ\text{C}$

MC7824AC

ELECTRICAL CHARACTERISTICS ($V_{in} = 33\text{ V}$, $I_O = 1.0\text{ A}$, $T_J = T_{low}$ to T_{high} [Note 1] unless otherwise noted).

Characteristics	Symbol	MC7824AC			Unit
		Min	Typ	Max	
Output Voltage ($T_J = +25^\circ\text{C}$)	V_O	23.5	24	24.5	Vdc
Output Voltage ($5.0\text{ mA} \leq I_O \leq 1.0\text{ A}$, $P_O \leq 15\text{ W}$) $27.3\text{ Vdc} \leq V_{in} \leq 38\text{ Vdc}$	V_O	23	24	25	Vdc
Line Regulation (Note 2) $27\text{ Vdc} \leq V_{in} \leq 38\text{ Vdc}$, $I_O = 500\text{ mA}$ $30\text{ Vdc} \leq V_{in} \leq 36\text{ Vdc}$ $30\text{ Vdc} \leq V_{in} \leq 36\text{ Vdc}$, $T_J = +25^\circ\text{C}$ $28.7\text{ Vdc} \leq V_{in} \leq 38\text{ Vdc}$, $T_J = +25^\circ\text{C}$	Regline	—	31	240	mV
Load Regulation (Note 2) $5.0\text{ mA} \leq I_O \leq 1.5\text{ A}$, $T_J = +25^\circ\text{C}$ $5.0\text{ mA} \leq I_O \leq 1.0\text{ A}$ $250\text{ mA} \leq I_O \leq 750\text{ mA}$, $T_J = +25^\circ\text{C}$ $250\text{ mA} \leq I_O \leq 750\text{ mA}$	Regload	—	60	100	mV
Quiescent Current $T_J = +25^\circ\text{C}$	I_B	—	4.6	6.0	mA
Quiescent Current Change $27.3\text{ Vdc} \leq V_{in} \leq 38\text{ Vdc}$, $I_O = 500\text{ mA}$ $27.3\text{ Vdc} \leq V_{in} \leq 38\text{ Vdc}$, $T_J = +25^\circ\text{C}$ $5.0\text{ mA} \leq I_O \leq 1.0\text{ A}$	ΔI_B	—	—	0.8	mA
Ripple Rejection $28\text{ Vdc} \leq V_{in} \leq 38\text{ Vdc}$, $f = 120\text{ Hz}$, $T_J = +25^\circ\text{C}$ $28\text{ Vdc} \leq V_{in} \leq 38\text{ Vdc}$, $f = 120\text{ Hz}$, $I_O = 500\text{ mA}$	RR	—	54	—	dB
Dropout Voltage ($I_O = 1.0\text{ A}$, $T_J = +25^\circ\text{C}$)	$V_{in} - V_O$	—	2.0	—	Vdc
Output Noise Voltage ($T_A = +25^\circ\text{C}$) $10\text{ Hz} \leq f \leq 100\text{ kHz}$	V_n	—	10	—	$\mu\text{V}/V_O$
Output Resistance ($f = 1.0\text{ kHz}$)	r_O	—	20	—	$\text{m}\Omega$
Short-Circuit Current Limit ($T_A = +25^\circ\text{C}$) $V_{in} = 35\text{ Vdc}$	I_{sc}	—	0.2	—	A
Peak Output Current ($T_J = +25^\circ\text{C}$)	I_{max}	—	2.2	—	A
Average Temperature Coefficient of Output Voltage	TCV_O	—	-1.5	—	$\text{mV}/^\circ\text{C}$

NOTES: 1. $T_{low} = -55^\circ\text{C}$ for MC78XX
 $= 0^\circ$ for MC78XXC, AC
 $= -40^\circ\text{C}$ for MC78XXB
 $T_{high} = +150^\circ\text{C}$ for MC78XX
 $= +125^\circ\text{C}$ for MC78XXC, AC, B

2. Load and line regulation are specified at constant junction temperature. Changes in V_O due to heating effects must be taken into account separately. Pulse testing with low duty cycle is used.

MC7800 Series

TYPICAL CHARACTERISTICS
($T_A = +25^\circ\text{C}$ unless otherwise noted.)

FIGURE 1 — WORST CASE POWER DISSIPATION versus AMBIENT TEMPERATURE (Case 221A)

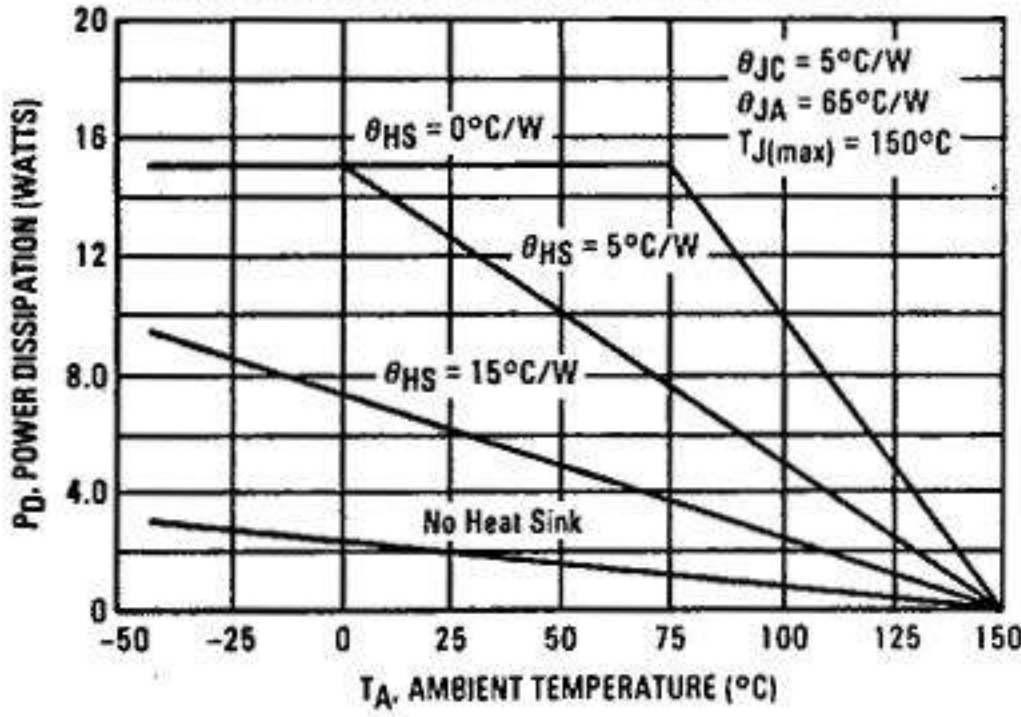

FIGURE 2 — WORST CASE POWER DISSIPATION versus AMBIENT TEMPERATURE (Case 1)

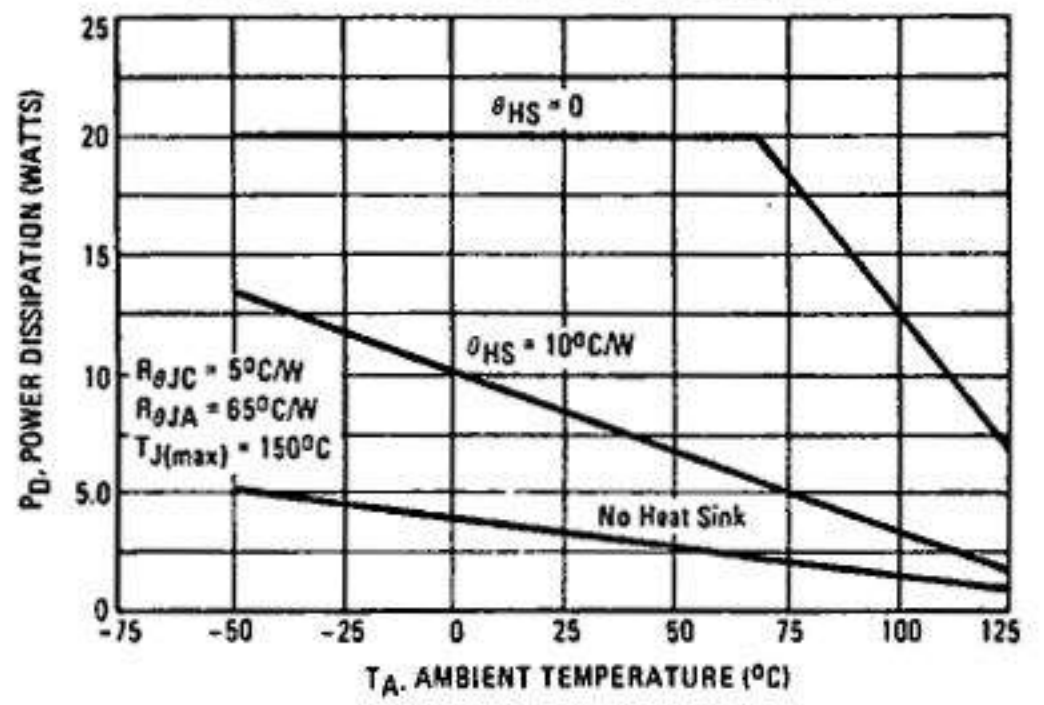

FIGURE 3 — INPUT OUTPUT DIFFERENTIAL AS A FUNCTION OF JUNCTION TEMPERATURE (MC78XXC, AC, B)

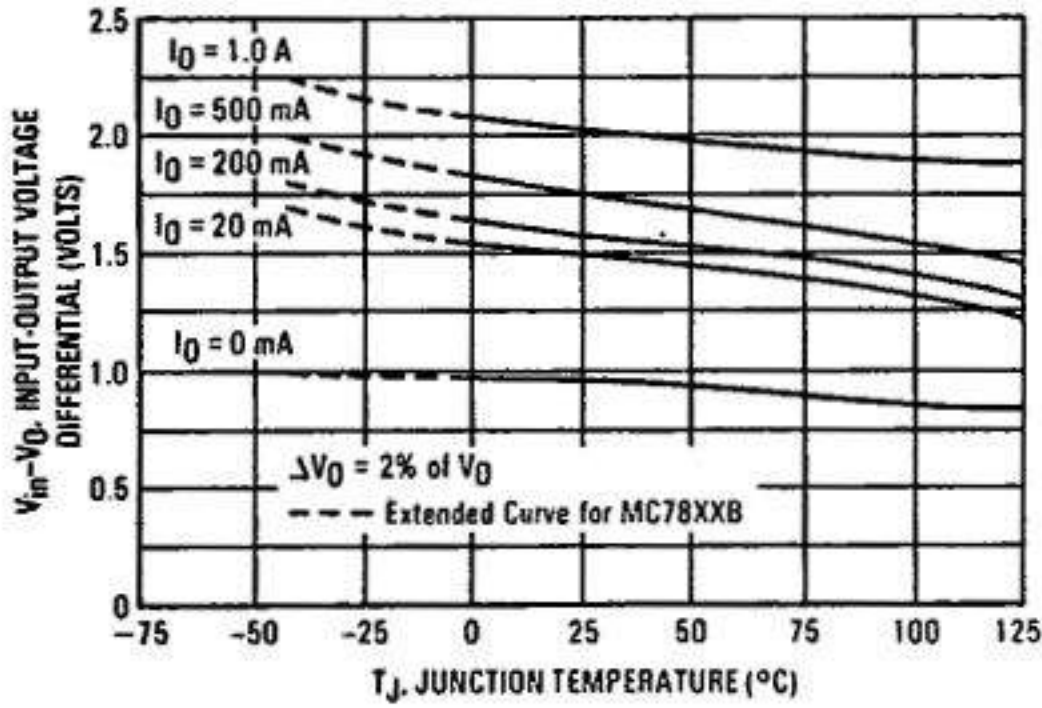

FIGURE 4 — INPUT OUTPUT DIFFERENTIAL AS A FUNCTION OF JUNCTION TEMPERATURE (MC78XX, A)

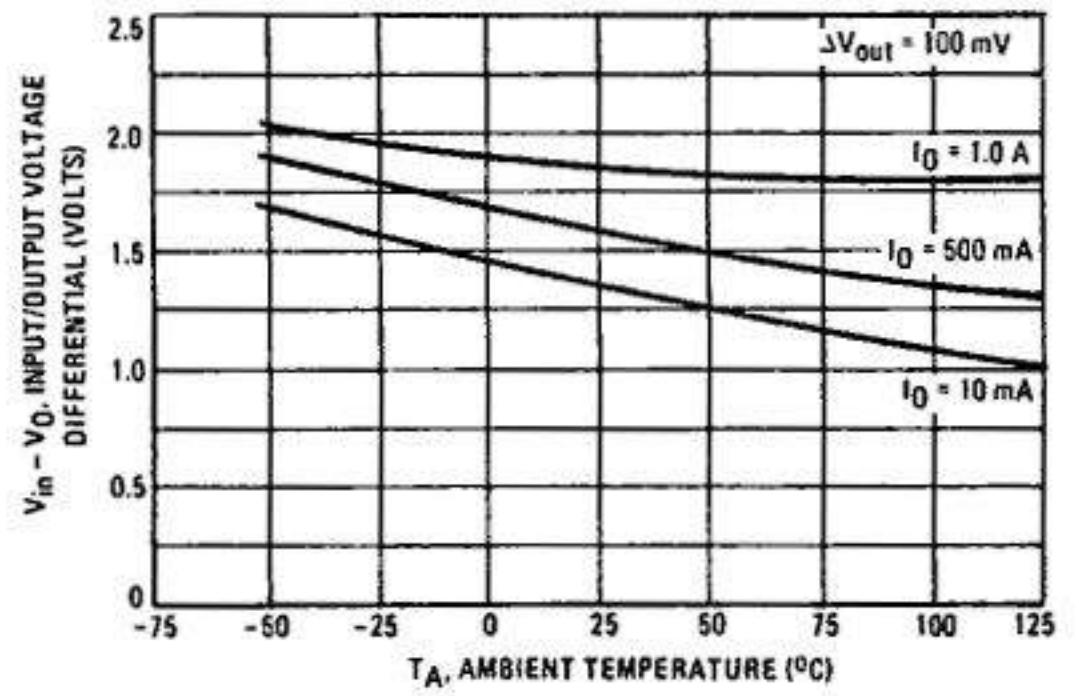

FIGURE 5 — PEAK OUTPUT CURRENT AS A FUNCTION OF INPUT-OUTPUT DIFFERENTIAL VOLTAGE (MC78XXC, AC, B)

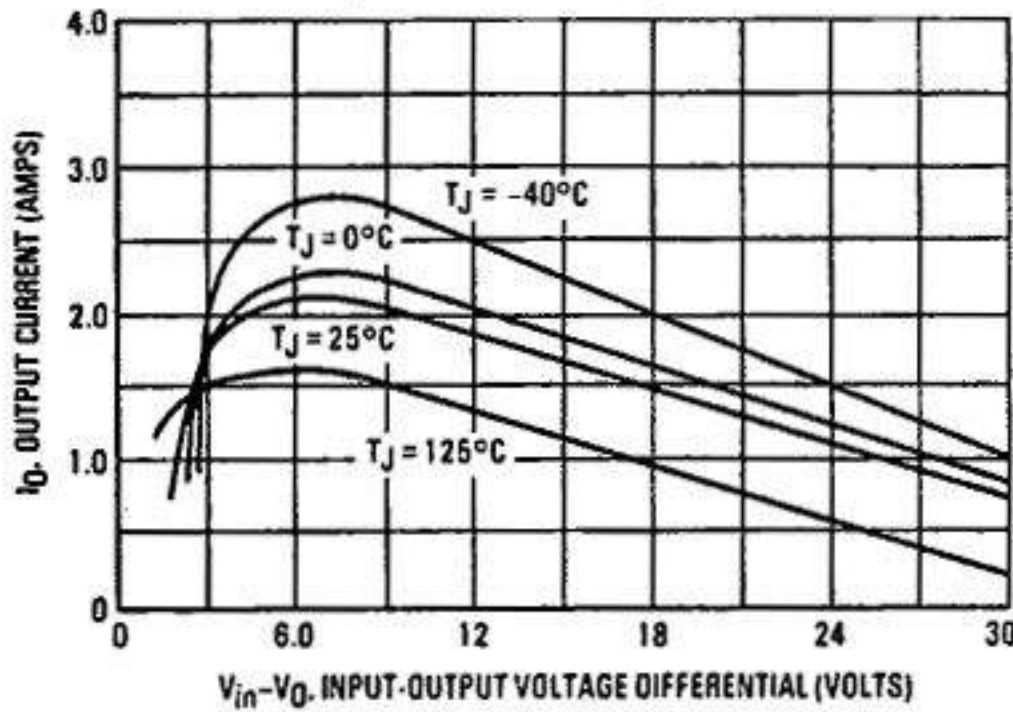
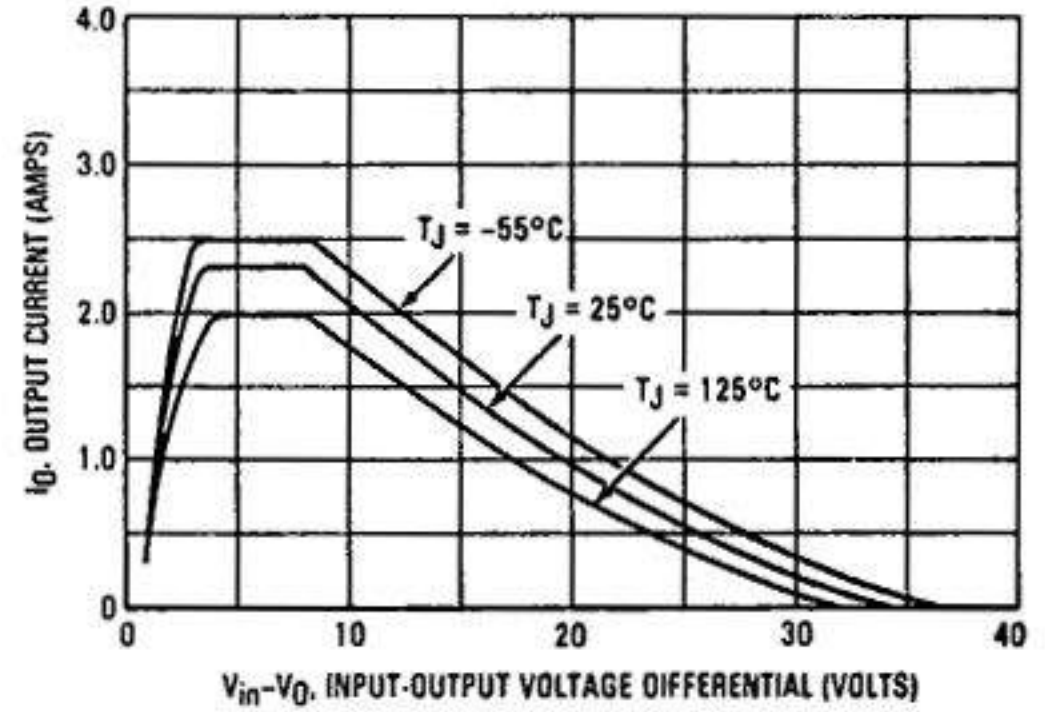

FIGURE 6 — PEAK OUTPUT CURRENT AS A FUNCTION OF INPUT-OUTPUT DIFFERENTIAL VOLTAGE (MC78XX, A)



MC7800 Series

TYPICAL CHARACTERISTICS (continued)
($T_A = 25^\circ\text{C}$ unless otherwise noted.)

FIGURE 7 - RIPPLE REJECTION AS A FUNCTION OF OUTPUT VOLTAGES (MC78XXC, AC)

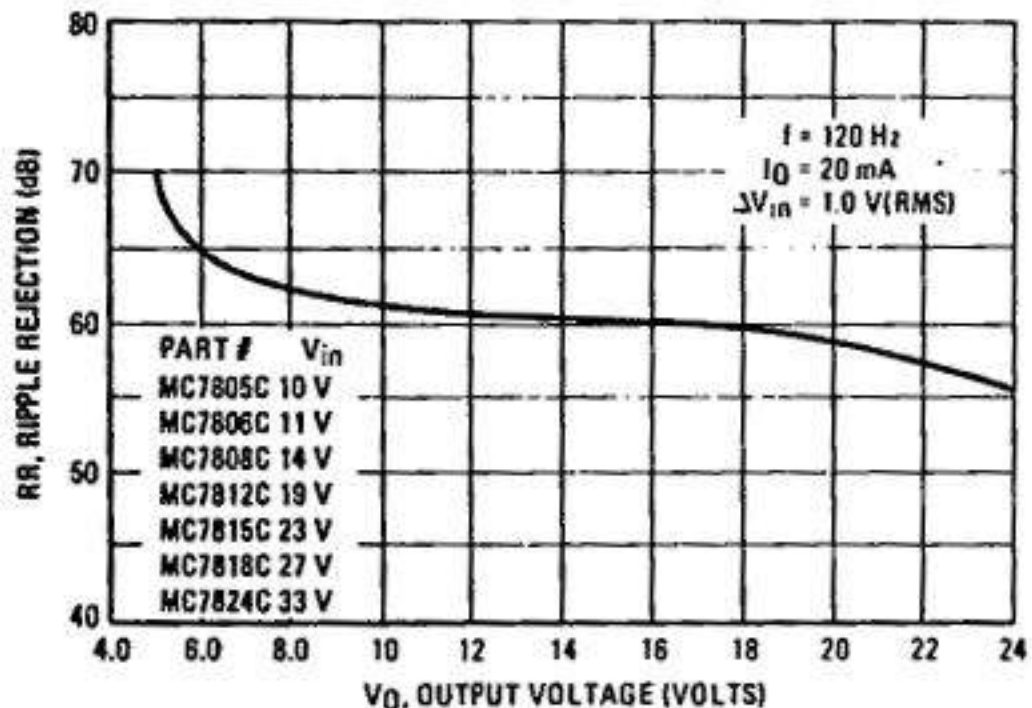

FIGURE 8 - RIPPLE REJECTION AS A FUNCTION OF FREQUENCY (MC78XXC, AC, A)

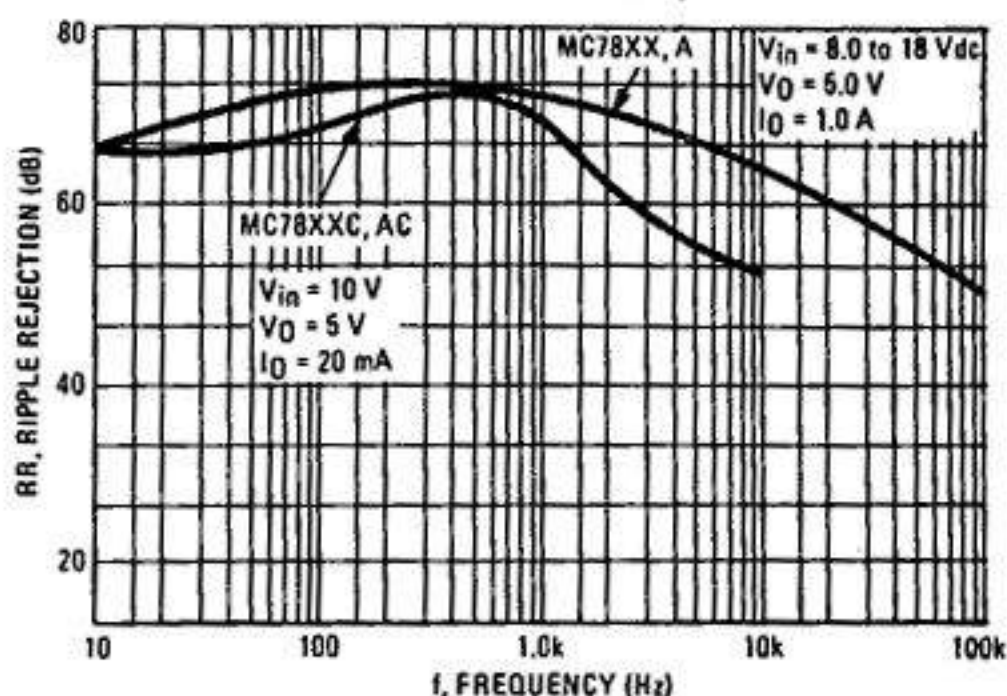

FIGURE 9 - OUTPUT VOLTAGE AS A FUNCTION OF JUNCTION TEMPERATURE (MC78XXC, AC, B)

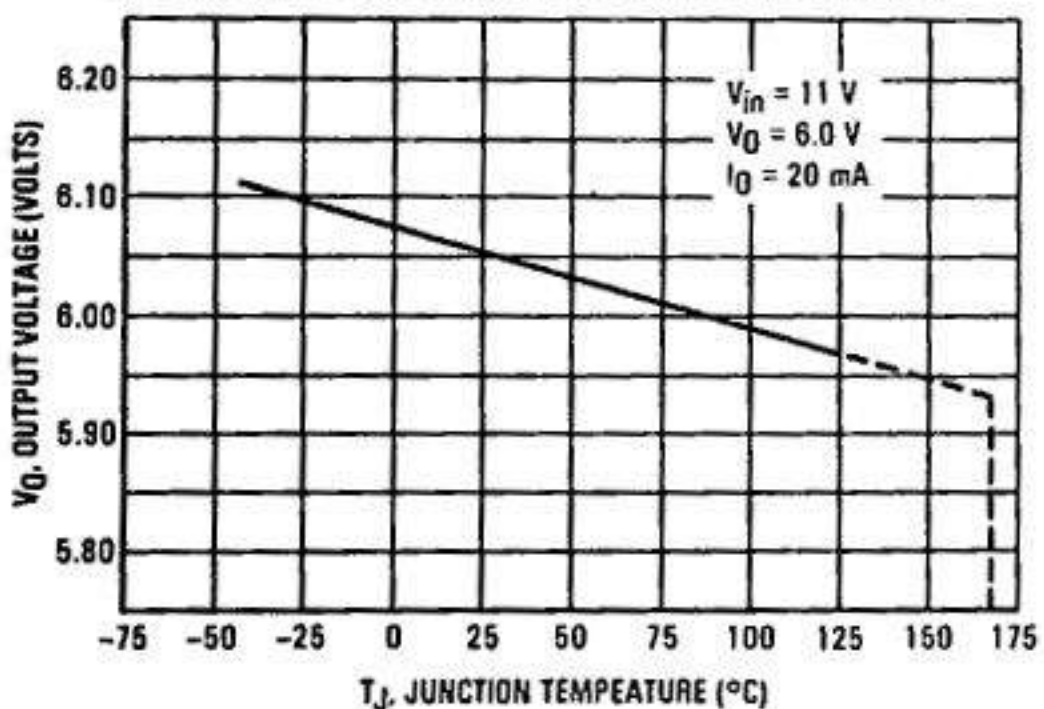

FIGURE 10 - OUTPUT IMPEDANCE AS A FUNCTION OF OUTPUT VOLTAGE (MC78XXC, AC)

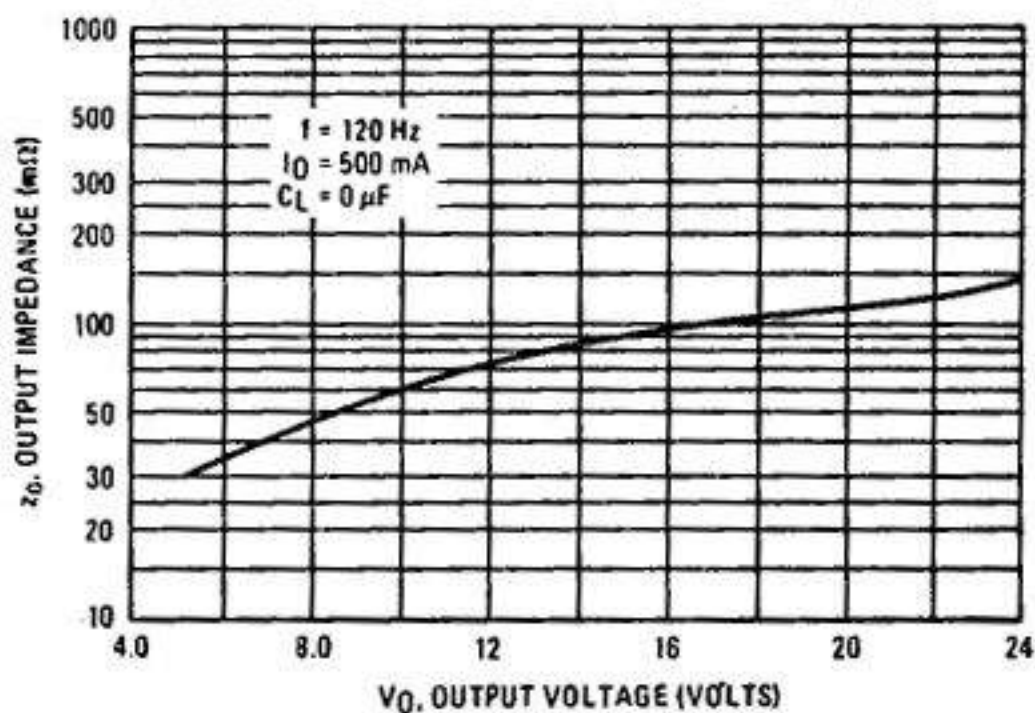

FIGURE 11 - QUIESCENT CURRENT AS A FUNCTION OF TEMPERATURE (MC78XXC, AC, B)

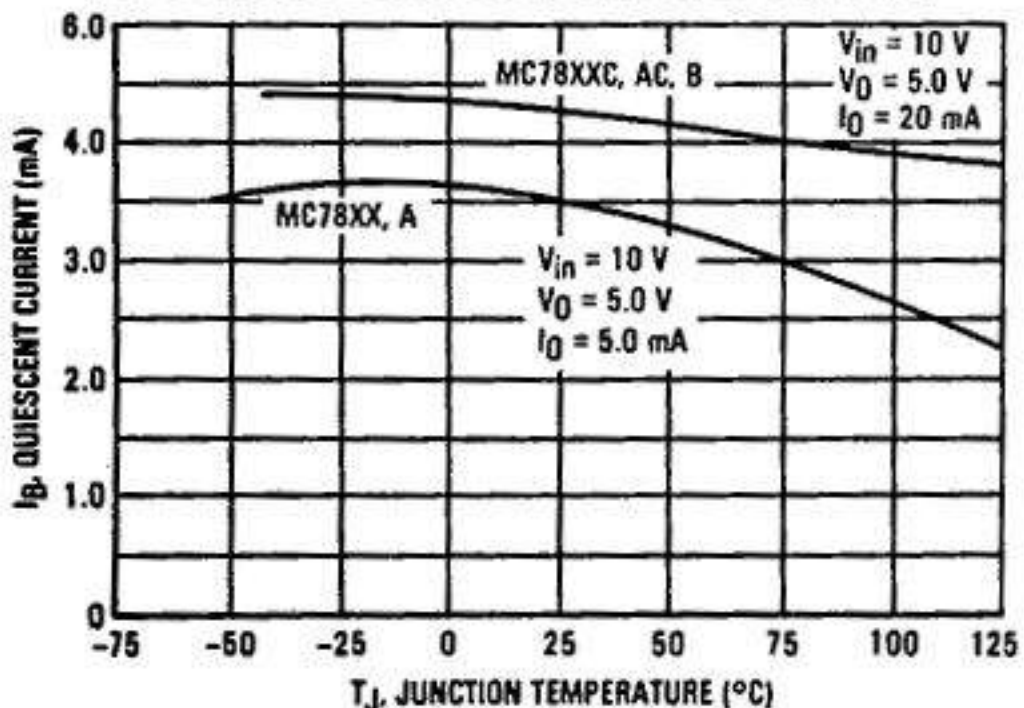
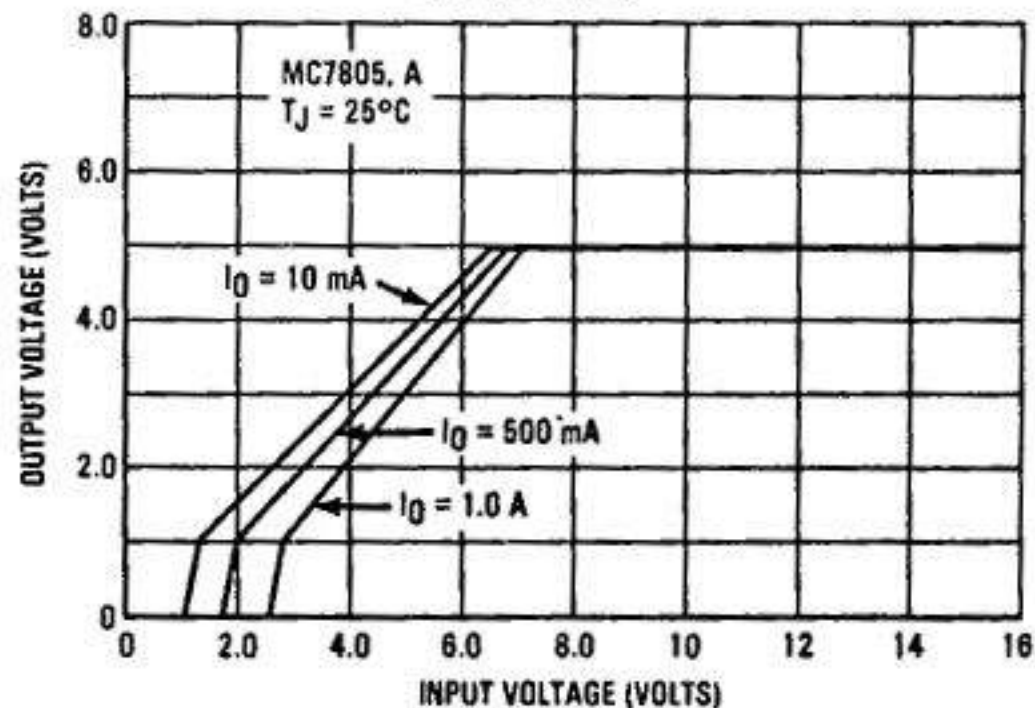

FIGURE 12 - DROPOUT CHARACTERISTICS (MC78XX, A)



MC7800 Series

APPLICATIONS INFORMATION

Design Considerations

The MC7800 Series of fixed voltage regulators are designed with Thermal Overload Protection that shuts down the circuit when subjected to an excessive power overload condition, Internal Short-Circuit Protection that limits the maximum current the circuit will pass, and Output Transistor Safe-Area Compensation that reduces the output short-circuit current as the voltage across the pass transistor is increased.

In many low current applications, compensation capacitors are not required. However, it is recommended that the regulator input be bypassed with a capacitor if the regulator is connected

to the power supply filter with long wire lengths, or if the output load capacitance is large. An input bypass capacitor should be selected to provide good high-frequency characteristics to insure stable operation under all load conditions. A 0.33 μF or larger tantalum, mylar, or other capacitor having low internal impedance at high frequencies should be chosen. The bypass capacitor should be mounted with the shortest possible leads directly across the regulator's input terminals. Normally good construction techniques should be used to minimize ground loops and lead resistance drops since the regulator has no external sense lead.

FIGURE 13 - CURRENT REGULATOR

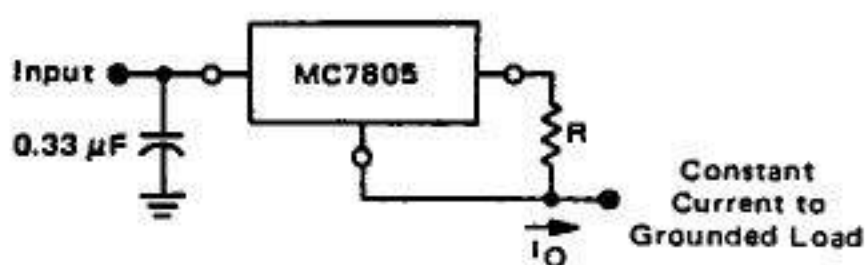

The MC7800 regulators can also be used as a current source when connected as above. In order to minimize dissipation the MC7805C is chosen in this application. Resistor R determines the current as follows:

$$I_O = \frac{5V}{R} + I_Q$$

$$I_Q \approx 1.5 \text{ mA over line and load changes}$$

For example, a 1-ampere current source would require R to be a 5-ohm, 10-W resistor and the output voltage compliance would be the input voltage less 7 volts.

FIGURE 14 - ADJUSTABLE OUTPUT REGULATOR

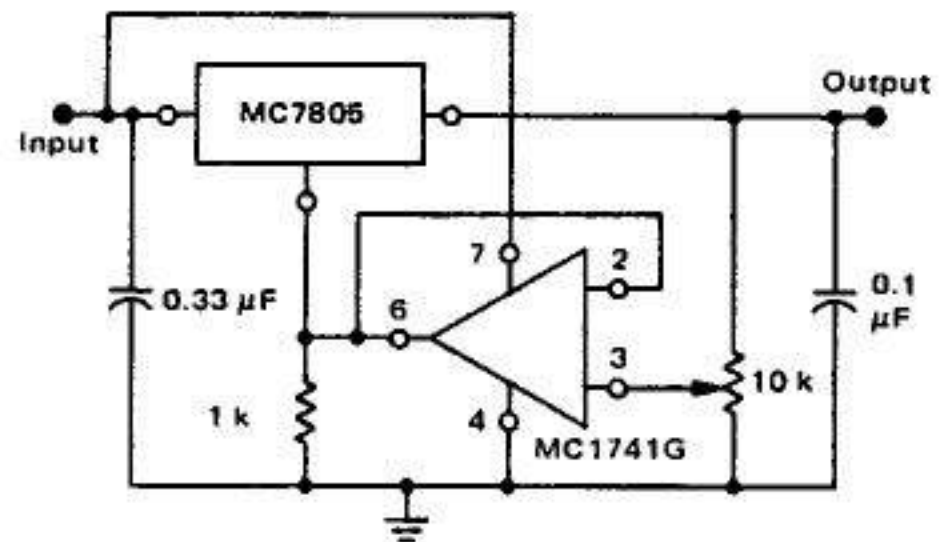

$$V_O, 7.0 \text{ V to } 20 \text{ V}$$

$$V_{IN} V_O \geq 2.0 \text{ V}$$

The addition of an operational amplifier allows adjustment to higher or intermediate values while retaining regulation characteristics. The minimum voltage obtainable with this arrangement is 2.0 volts greater than the regulator voltage.

FIGURE 15 - CURRENT BOOST REGULATOR

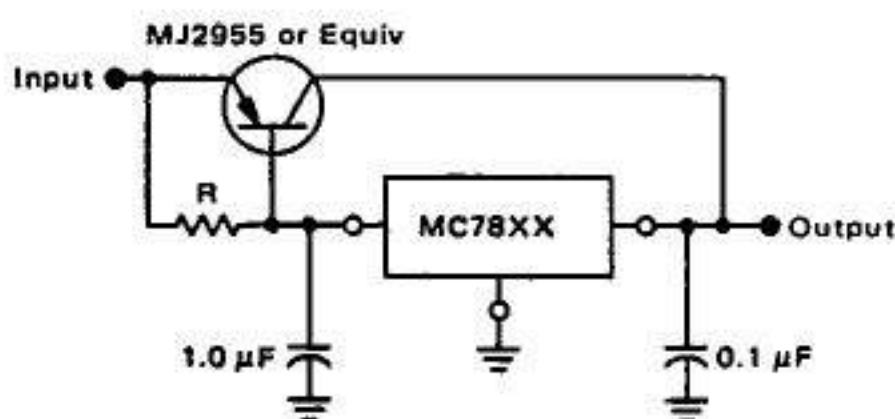

XX = 2 digits of type number indicating voltage.

The MC7800 series can be current boosted with a PNP transistor. The MJ2955 provides current to 5.0 amperes. Resistor R in conjunction with the V_{BE} of the PNP determines when the pass transistor begins conducting; this circuit is not short-circuit proof. Input-output differential voltage minimum is increased by V_{BE} of the pass transistor.

FIGURE 16 - SHORT-CIRCUIT PROTECTION

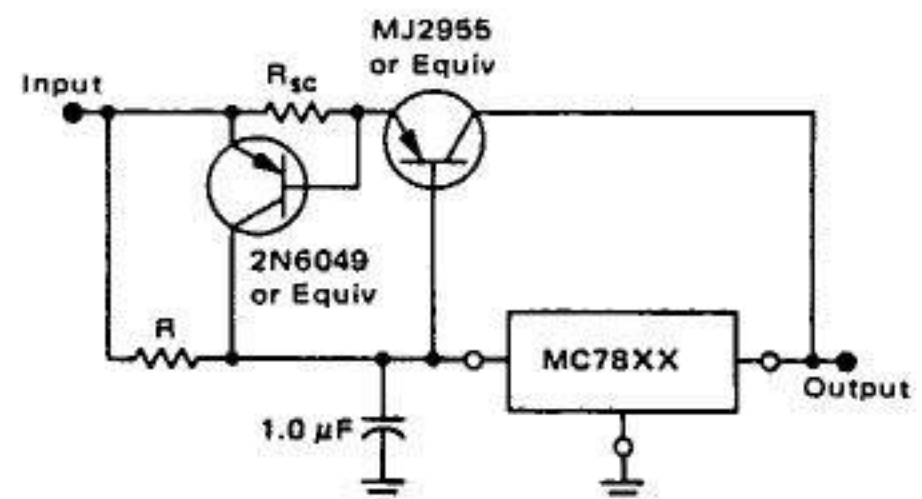

XX = 2 digits of type number indicating voltage.

The circuit of Figure 16 can be modified to provide supply protection against short circuits by adding a short-circuit sense resistor, R_{SC}, and an additional PNP transistor. The current sensing PNP must be able to handle the short-circuit current of the three-terminal regulator. Therefore, a four-ampere plastic power transistor is specified.

SECTION 19

PACKAGE OUTLINE DIMENSIONS

DIM	MILLIMETERS		INCHES	
	MIN	MAX	MIN	MAX
B	—	22.23	—	0.875
C	8.35	11.43	0.250	0.450
D	0.97	1.09	0.038	0.043
E	—	3.43	—	0.135
F	30.15 BSC	—	1.187 BSC	—
G	10.92 BSC	—	0.430 BSC	—
H	5.46 BSC	—	0.215 BSC	—
J	16.89 BSC	—	0.665 BSC	—
K	7.92	—	0.312	—
Q	3.84	4.09	0.151	0.161
S	—	13.34	—	0.525
T	—	4.78	—	0.189
V	3.84	4.09	0.151	0.161

K SUFFIX
METAL PACKAGE
CASE 1-03
 $R_{\theta JA} = 45^{\circ}\text{C/W (TYP)}$
(TO-3)

- NOTES:
 1. DIAMETER V AND SURFACE W ARE DATUMS.
 2. POSITIONAL TOLERANCE FOR HOLE Q:
 $\pm \phi 0.25 (0.010) \text{ (M) W | V (M)}$
 3. POSITIONAL TOLERANCE FOR LEADS:
 $\pm \phi 0.30 (0.012) \text{ (M) W | V (M) Q (M)}$

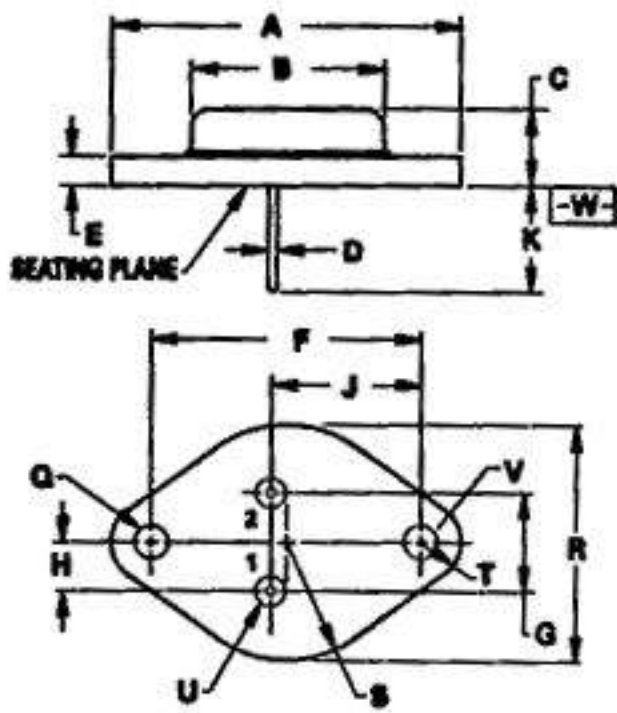

DIM	MILLIMETERS		INCHES	
	MIN	MAX	MIN	MAX
A	4.32	5.33	0.170	0.210
B	4.45	5.20	0.175	0.205
C	3.18	4.19	0.125	0.165
D	0.41	0.55	0.016	0.022
F	0.41	0.48	0.016	0.019
G	1.15	1.39	0.045	0.055
H	—	2.54	—	0.100
J	2.42	2.66	0.095	0.105
K	12.70	—	0.500	—
L	6.35	—	0.250	—
N	2.04	2.68	0.080	0.105
P	2.93	—	0.115	—
R	3.43	—	0.135	—
S	0.39	0.50	0.015	0.020

LP, P, Z SUFFIX
PLASTIC PACKAGE
CASE 29-04
 $R_{\theta JA} = 200^{\circ}\text{C/W (TYP)}$
(TO-226AA/TO-92)

- NOTES:
 1. CONTOUR OF PACKAGE BEYOND ZONE "P" IS UNCONTROLLED.
 2. DIM "P" APPLIES BETWEEN "H" AND "L". DIM "D" & "S" APPLIES BETWEEN "L" & 12.70mm (0.5") FROM SEATING PLANE. LEAD DIM IS UNCONTROLLED IN "H" & BEYOND 12.70mm (0.5") FROM SEATING PLANE.
 3. CONTROLLING DIM: INCH.

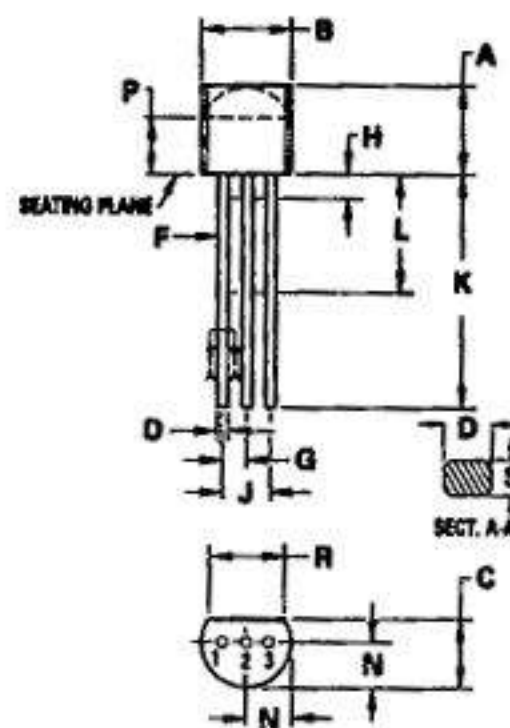

DIM	MILLIMETERS		INCHES	
	MIN	MAX	MIN	MAX
A	8.02	9.29	0.355	0.368
B	8.01	8.50	0.315	0.335
C	4.20	4.57	0.165	0.180
D	0.44	0.53	0.017	0.021
E	0.44	0.88	0.017	0.035
F	0.41	0.48	0.016	0.019
G	5.08 BSC	—	0.200 BSC	—
H	0.72	0.86	0.028	0.034
J	0.74	1.01	0.029	0.040
K	12.70	19.05	0.500	0.750
L	6.35	—	0.250	—
M	45° BSC	—	45° BSC	—
P	—	1.27	—	0.050
R	2.54	—	0.100	—

G, H SUFFIX
METAL PACKAGE
CASE 79-05
 $R_{\theta JA} = 185^{\circ}\text{C/W (TYP)}$
(TO-39)

- NOTES:
 1. DIMENSIONING AND TOLERANCING PER ANSI Y14.5M, 1982.
 2. CONTROLLING DIMENSION: INCH.
 3. DIMENSION J MEASURED FROM DIMENSION A MAXIMUM.
 4. DIMENSION B SHALL NOT VARY MORE THAN 0.25 (0.010) IN ZONE R. THIS ZONE CONTROLLED FOR AUTOMATIC HANDLING.
 5. DIMENSION F APPLIES BETWEEN DIMENSION P AND L. DIMENSION D APPLIES BETWEEN DIMENSION L AND K MINIMUM. LEAD DIAMETER IS UNCONTROLLED IN DIMENSION P AND BEYOND DIMENSION K MINIMUM.

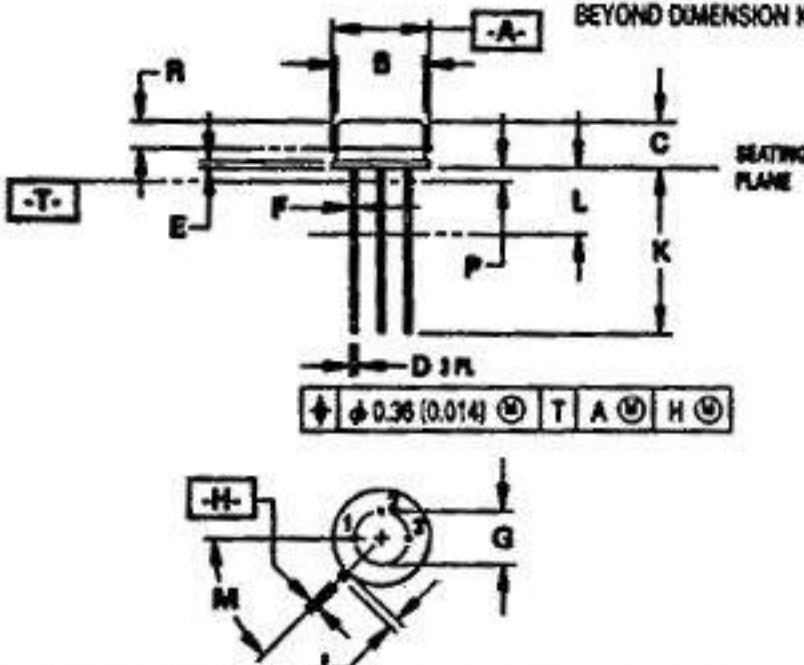

DIM	MILLIMETERS		INCHES	
	MIN	MAX	MIN	MAX
A	14.48	15.75	0.570	0.620
B	9.68	10.28	0.380	0.405
C	4.07	4.82	0.160	0.190
D	0.64	0.88	0.025	0.035
F	3.81	3.73	0.142	0.147
G	2.42	2.68	0.095	0.105
H	2.80	3.93	0.110	0.155
J	0.38	0.56	0.014	0.022
K	12.70	14.27	0.500	0.562
L	1.15	1.39	0.045	0.055
N	4.83	5.33	0.190	0.210
Q	2.54	3.04	0.100	0.120
R	2.04	2.79	0.080	0.110
S	1.15	1.39	0.045	0.055
T	5.97	6.47	0.235	0.255
U	0.00	1.27	0.000	0.050
V	1.15	—	0.045	—
Z	—	2.04	—	0.080

KC, T SUFFIX
PLASTIC PACKAGE
CASE 221A-04
 $R_{\theta JA} = 65^{\circ}\text{C/W (TYP)}$
(TO-220AB)

- NOTES:
 1. DIMENSIONING AND TOLERANCING PER ANSI Y14.5M, 1982.
 2. CONTROLLING DIMENSION: INCH.
 3. DIM Z DEFINES A ZONE WHERE ALL BODY AND LEAD IRREGULARITIES ARE ALLOWED.

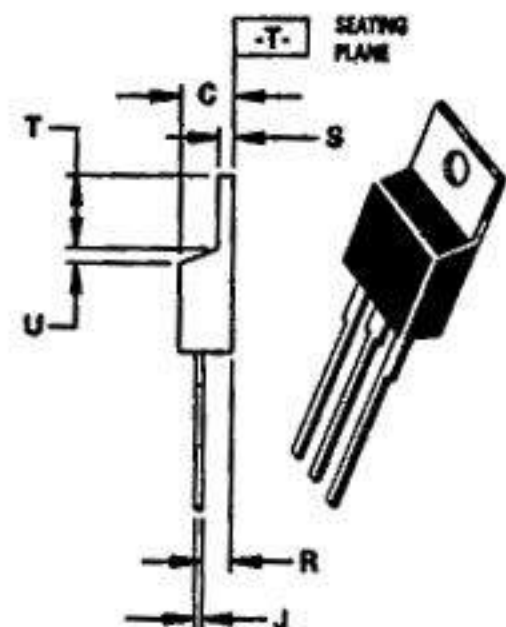
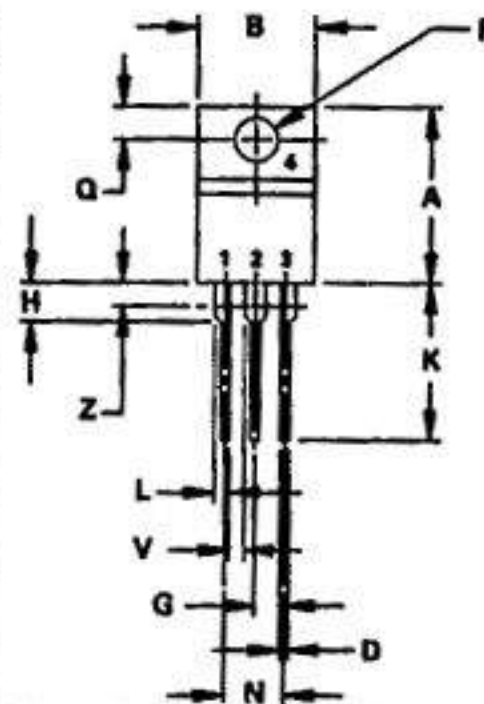

PACKAGE OUTLINE DIMENSIONS (continued)

DIM	MILLIMETERS		INCHES	
	MIN	MAX	MIN	MAX
A	14.529	15.570	0.572	0.613
B	9.908	10.541	0.390	0.415
C	4.318	4.572	0.170	0.180
D	0.635	0.965	0.025	0.038
E	1.189	1.397	0.046	0.055
G	1.702 BSC		0.067 BSC	
H	2.109	2.717	0.083	0.107
J	0.381	0.635	0.015	0.025
K	25.807	26.670	1.016	1.050
L	8.052	9.398	0.317	0.370
Q	3.556	3.937	0.140	0.155
U	11.889	12.827	0.468	0.505

T SUFFIX
PLASTIC PACKAGE
CASE 314D-02

NOTES:
1. DIMENSIONING AND TOLERANCING PER ANSI Y14.5M, 1982.
2. CONTROLLING DIMENSION: INCH.

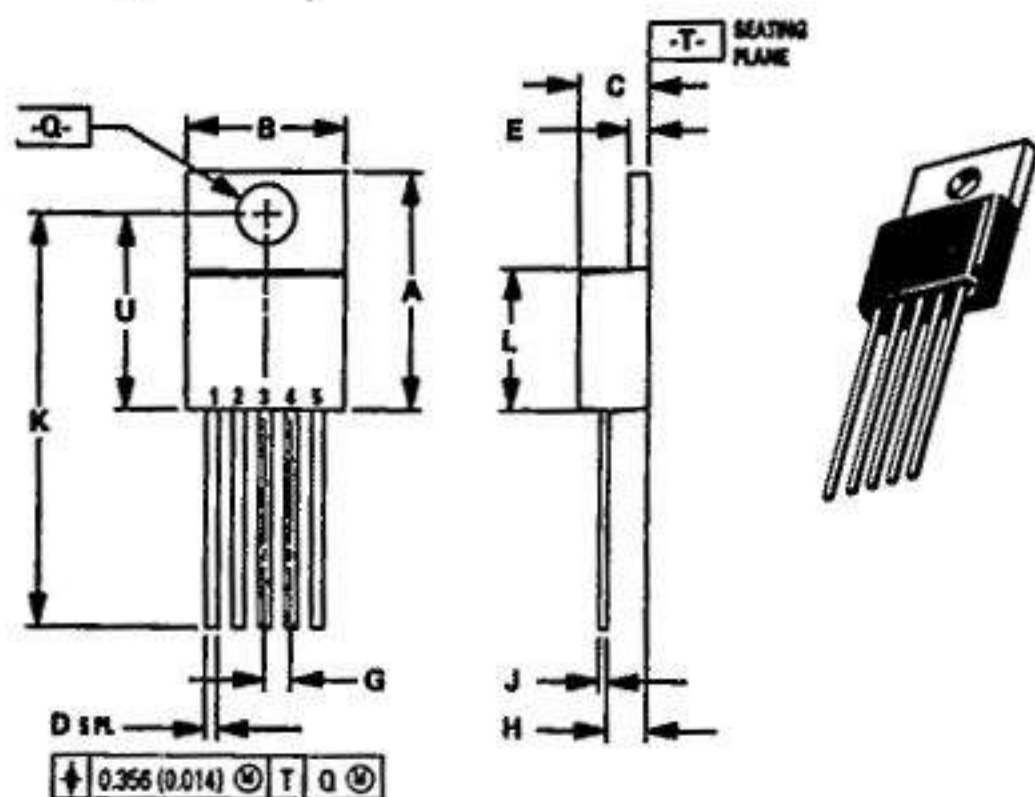

DIM	MILLIMETERS		INCHES	
	MIN	MAX	MIN	MAX
A	5.97	6.22	0.235	0.245
B	6.35	6.73	0.250	0.265
C	2.19	2.38	0.086	0.094
D	0.69	0.88	0.027	0.035
E	0.84	0.94	0.033	0.037
F	0.77	1.14	0.030	0.045
G	2.29 BSC		0.090 BSC	
H	0.97	1.06	0.038	0.042
J	0.46	0.58	0.018	0.023
K	8.89	9.65	0.350	0.380
R	5.21	5.46	0.205	0.215
S	1.91	2.28	0.075	0.090
V	0.89	1.27	0.035	0.050

DT-1 SUFFIX
PLASTIC PACKAGE
CASE 369-03

NOTES:
1. DIMENSIONING AND TOLERANCING PER ANSI Y14.5M, 1982.
2. CONTROLLING DIMENSION: INCH.

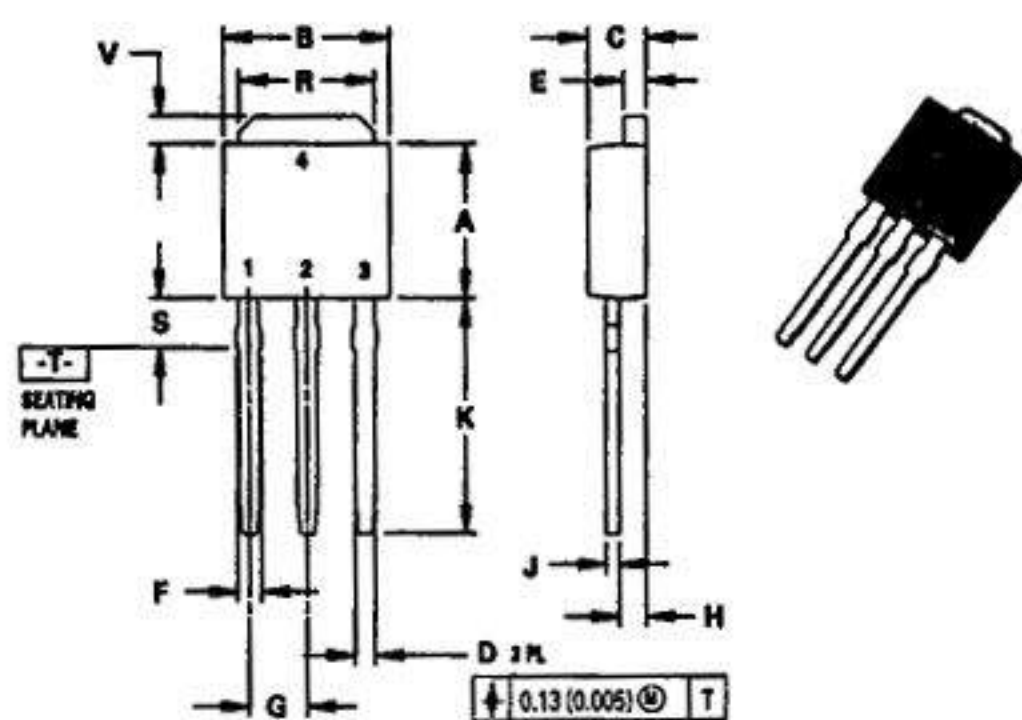

DIM	MILLIMETERS		INCHES	
	MIN	MAX	MIN	MAX
A	5.97	6.22	0.235	0.245
B	6.35	6.73	0.250	0.265
C	2.19	2.38	0.086	0.094
D	0.69	0.88	0.027	0.035
E	0.84	0.94	0.033	0.037
F	0.77	1.14	0.030	0.045
G	4.58 BSC		0.180 BSC	
H	0.97	1.06	0.038	0.042
J	0.46	0.58	0.018	0.023
K	2.60	2.89	0.102	0.114
L	2.29 BSC		0.090 BSC	
R	5.21	5.46	0.205	0.215
S	0.64	0.88	0.025	0.035
U	0.51	—	0.020	—
V	0.89	1.27	0.035	0.050
Y	4.32	—	0.170	—

DT SUFFIX
PLASTIC PACKAGE
CASE 369A-03
DPAK

NOTES:
1. DIMENSIONING AND TOLERANCING PER ANSI Y14.5M, 1982.
2. CONTROLLING DIMENSION: INCH.

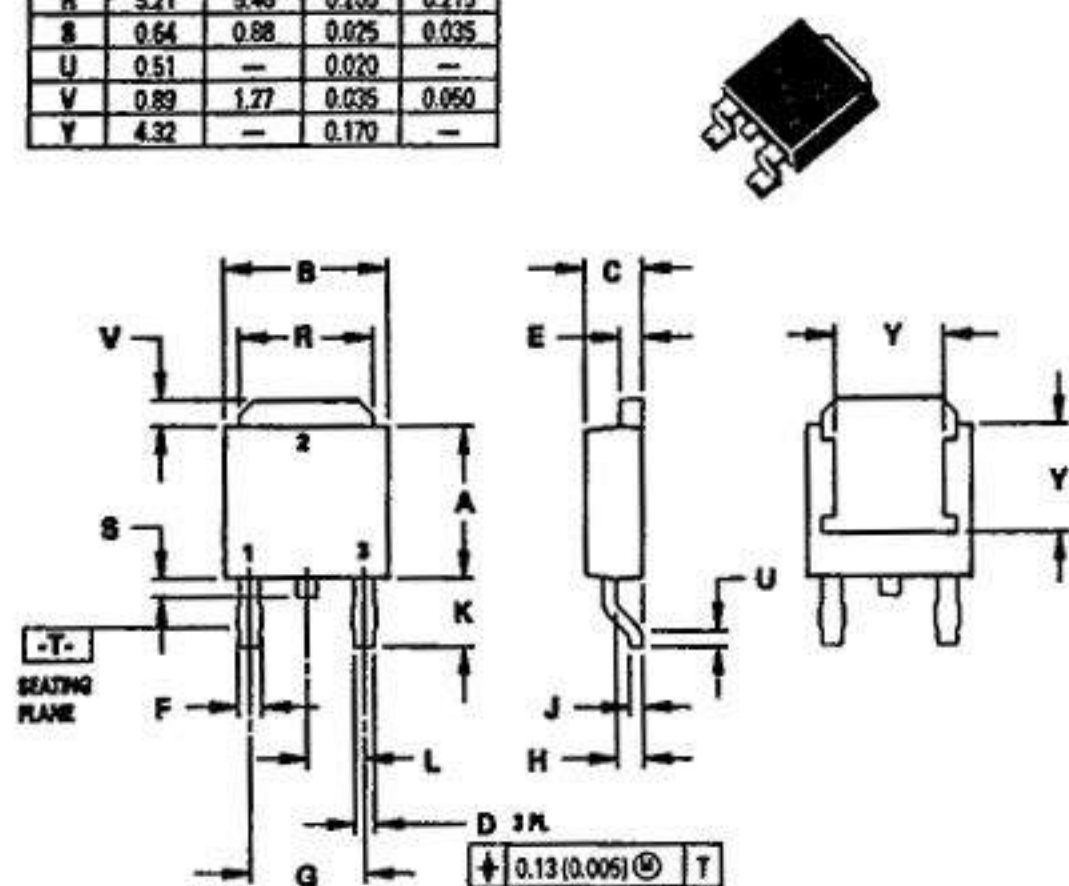

DIM	MILLIMETERS		INCHES	
	MIN	MAX	MIN	MAX
A	8.51	9.39	0.335	0.370
B	7.75	8.51	0.305	0.335
C	4.19	4.70	0.165	0.185
D	0.407	0.533	0.016	0.021
E	—	1.02	—	0.040
F	0.406	0.483	0.016	0.019
G	5.84 BSC		0.230 BSC	
H	0.712	0.864	0.028	0.034
J	0.737	1.14	0.029	0.045
K	12.70	—	0.500	—
L	6.35	12.70	0.250	0.500
M	36° BSC		36° BSC	
P	—	1.27	—	0.050
Q	3.55	4.06	0.140	0.160
R	0.254	1.02	0.010	0.040

H, G SUFFIX
METAL PACKAGE
CASE 603-04
 $R_{\theta JA} = 160^{\circ}\text{C/W}$
(TO-100)

NOTE:
LEADS WITHIN 0.18 mm (0.007) RADIUS OF TRUE POSITION AT SEATING PLANE AT MAXIMUM MATERIAL CONDITION.

All JEDEC Dimensions and Notes Apply.

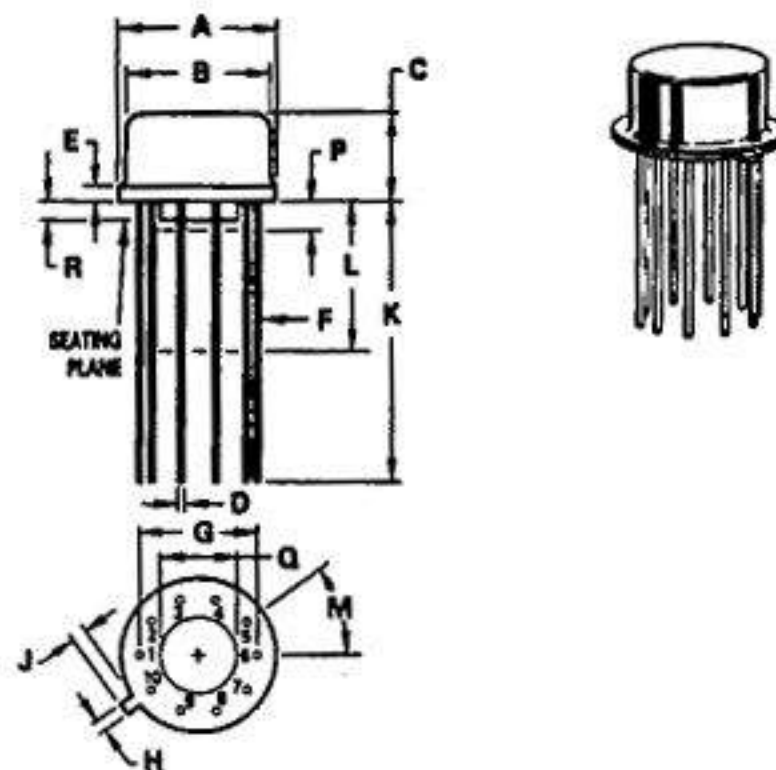

PACKAGE OUTLINE DIMENSIONS (continued)

DIM	MILLIMETERS		INCHES	
	MIN	MAX	MIN	MAX
A	8.51	9.39	0.335	0.370
B	7.75	8.51	0.305	0.335
C	4.19	6.73	0.165	0.265
D	0.407	0.533	0.016	0.021
E	—	1.02	—	0.040
F	0.406	0.483	0.016	0.019
G	5.84 BSC		0.230 BSC	
H	0.212	0.864	0.028	0.034
J	0.737	1.14	0.029	0.045
K	12.70	—	0.500	—
L	6.35	12.70	0.250	0.500
M	36° BSC		36° BSC	
P	—	1.27	—	0.050
Q	3.56	4.06	0.140	0.160
R	0.254	1.02	0.010	0.040

**G SUFFIX
METAL PACKAGE
CASE 603C-01**
 $R_{\theta JA} = 150^{\circ}\text{C/W (TYP)}$
(TO-100)

- NOTES:
1. LEADS WITHIN 0.18 mm (0.007) RADIUS OF TRUE POSITION TO DIM. "A" & "H" AT SEATING PLANE AT MAXIMUM MATERIAL CONDITION.
2. LEAD DIA UNCONTROLLED BEYOND DIM "K" MIN.

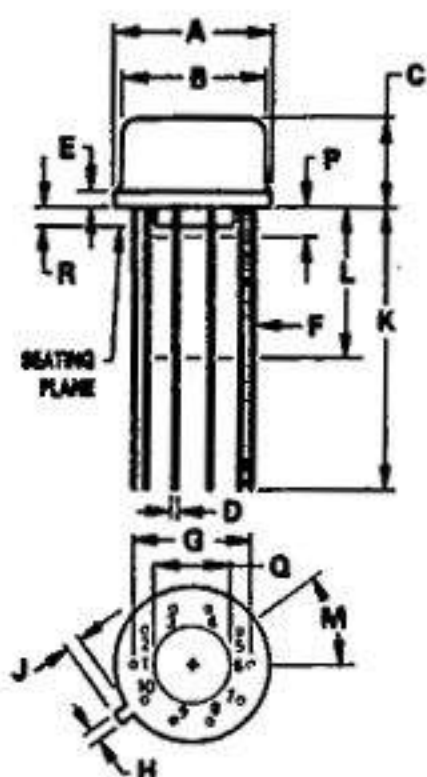

DIM	MILLIMETERS		INCHES	
	MIN	MAX	MIN	MAX
A	19.05	19.94	0.750	0.785
B	6.10	7.49	0.240	0.295
C	—	5.08	—	0.200
D	0.38	0.53	0.015	0.021
F	1.40	1.78	0.055	0.070
G	2.54 BSC		0.100 BSC	
H	0.51	1.14	0.020	0.045
J	0.20	0.30	0.008	0.012
K	3.18	4.32	0.125	0.170
L	7.62 BSC		0.300 BSC	
M	—	15°	—	15°
N	0.51	1.02	0.020	0.040

**DP2, D, J, L, N SUFFIX
CERAMIC PACKAGE
CASE 620-10**
 $R_{\theta JA} = 100^{\circ}\text{C/W (TYP)}$

- NOTES:
1. LEADS WITHIN 0.13 mm (0.005) RADIUS OF TRUE POSITION AT SEATING PLANE AT MAXIMUM MATERIAL CONDITION.
2. PACKAGE INDEX: NOTCH IN LEAD NOTCH IN CERAMIC OR INK DOT.
3. DIM "L" TO CENTER OF LEADS WHEN FORMED PARALLEL.
4. DIM "A" AND "B" DO NOT INCLUDE GLASS RUN-OUT.
5. DIM "F" MAY NARROW TO 0.76 mm (0.030) WHERE THE LEAD ENTERS THE CERAMIC BODY.

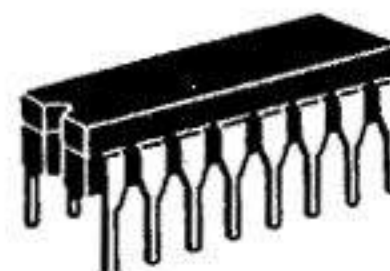
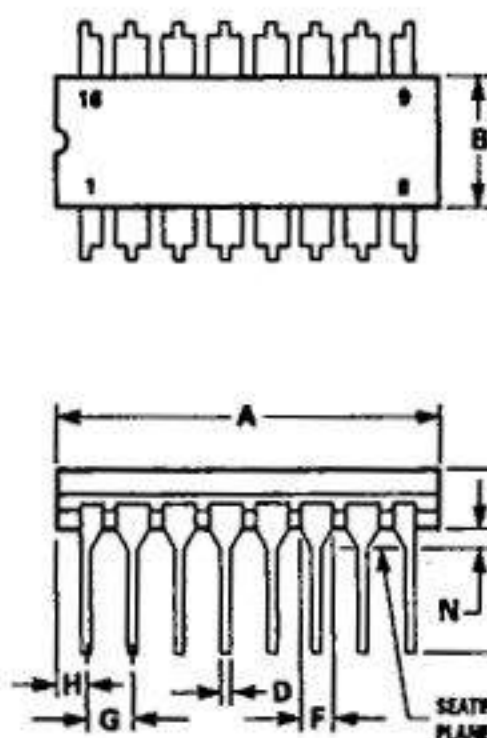

DIM	MILLIMETERS		INCHES	
	MIN	MAX	MIN	MAX
A	9.40	10.16	0.370	0.400
B	6.10	6.50	0.240	0.260
C	3.94	4.45	0.155	0.175
D	0.38	0.51	0.015	0.020
F	1.02	1.52	0.040	0.060
G	2.54 BSC		0.100 BSC	
H	0.76	1.27	0.030	0.050
J	0.20	0.30	0.008	0.012
K	2.92	3.43	0.115	0.135
L	7.62 BSC		0.300 BSC	
M	—	10°	—	10°
N	0.76	1.01	0.030	0.040

**N, P1 SUFFIX
PLASTIC PACKAGE
CASE 626-05**
 $R_{\theta JA} = 100^{\circ}\text{C/W (TYP)}$

- NOTES:
1. LEAD POSITIONAL TOLERANCE:
 $\pm 0.13 (0.005) \text{ T A B}$
2. DIMENSION L TO CENTER OF LEADS WHEN FORMED PARALLEL.
3. PACKAGE CONTOUR OPTIONAL (ROUND OR SQUARE CORNERS).
4. DIMENSIONS A AND B ARE DATUMS.
5. DIMENSIONING AND TOLERANCING PER ANSI Y14.5M, 1982.

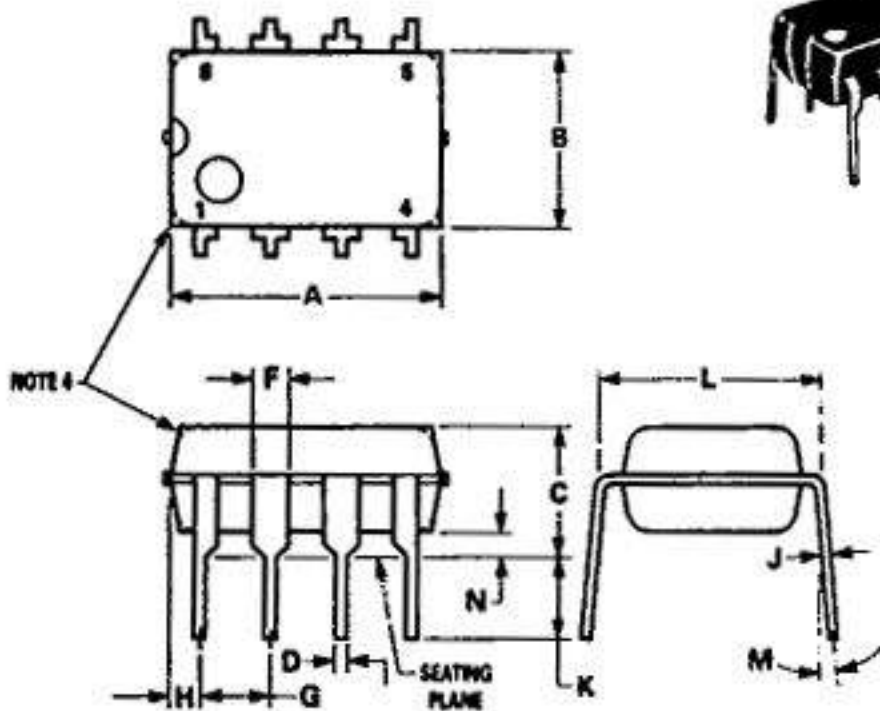

DIM	MILLIMETERS		INCHES	
	MIN	MAX	MIN	MAX
A	19.05	19.94	0.750	0.785
B	6.23	7.11	0.245	0.280
C	3.94	5.08	0.155	0.200
D	0.39	0.50	0.015	0.020
F	1.40	1.65	0.055	0.065
G	2.54 BSC		0.100 BSC	
J	0.21	0.38	0.008	0.015
K	3.18	4.31	0.125	0.170
L	7.62 BSC		0.300 BSC	
M	0°	15°	0°	15°
N	0.51	1.01	0.020	0.040

**L SUFFIX
CERAMIC PACKAGE
CASE 632-08**
 $R_{\theta JA} = 100^{\circ}\text{C/W (TYP)}$
(TO-116)

- NOTES:
1. DIMENSIONING AND TOLERANCING PER ANSI Y14.5M, 1982.
2. CONTROLLING DIMENSION: INCH.
3. DIMENSION L TO CENTER OF LEAD WHEN FORMED PARALLEL.
4. DIM F MAY NARROW TO 0.76 (0.030) WHERE THE LEAD ENTERS THE CERAMIC BODY.

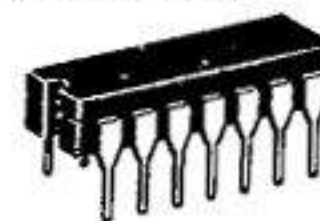
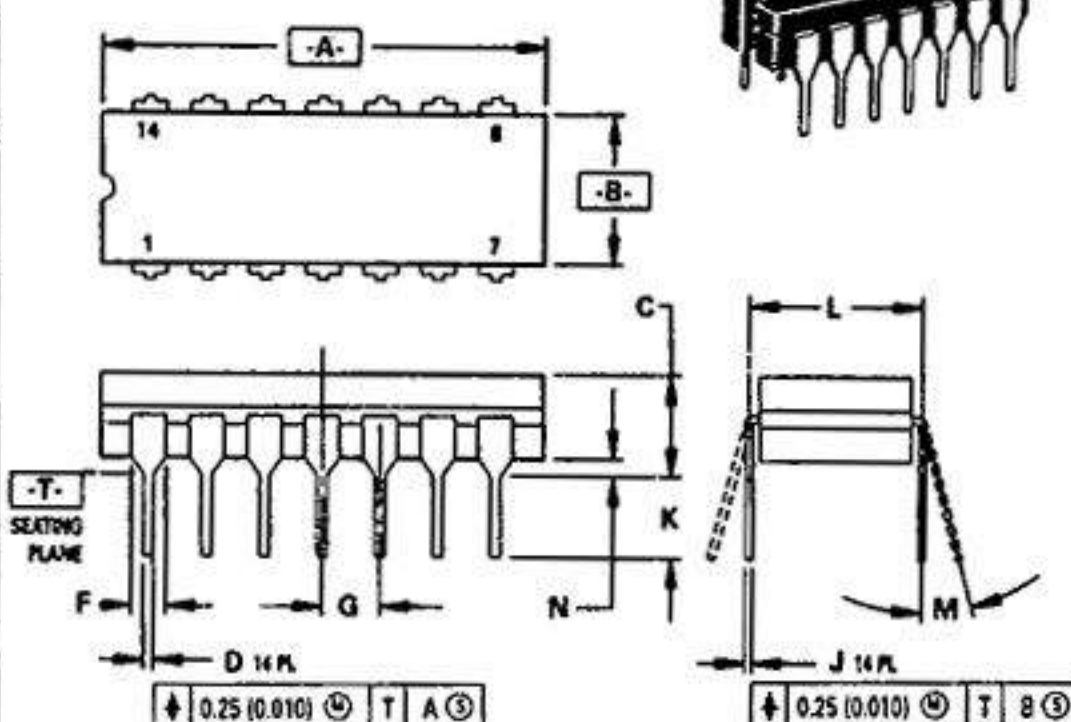

PACKAGE OUTLINE DIMENSIONS (continued)

**N, P, N-14, P2 SUFFIX
PLASTIC PACKAGE
CASE 646-06**

$R_{\theta JA} = 100^{\circ}\text{C/W (TYP)}$

DIM	MILLIMETERS		INCHES	
	MIN	MAX	MIN	MAX
A	18.16	19.56	0.715	0.770
B	6.10	6.60	0.240	0.260
C	3.69	4.69	0.145	0.185
D	0.38	0.53	0.015	0.021
F	1.02	1.78	0.040	0.070
G	2.54 BSC		0.100 BSC	
H	1.32	2.41	0.052	0.095
J	0.20	0.38	0.008	0.015
K	2.92	3.43	0.115	0.135
L	7.62 BSC		0.300 BSC	
M	0°	10°	0°	10°
N	0.39	1.01	0.015	0.039

- NOTES:
- LEADS WITHIN 0.13 mm (0.005) RADIUS OF TRUE POSITION AT SEATING PLANE AT MAXIMUM MATERIAL CONDITION.
 - DIMENSION "L" TO CENTER OF LEADS WHEN FORMED PARALLEL.
 - DIMENSION "B" DOES NOT INCLUDE MOLD FLASH.
 - ROUNDED CORNERS OPTIONAL.

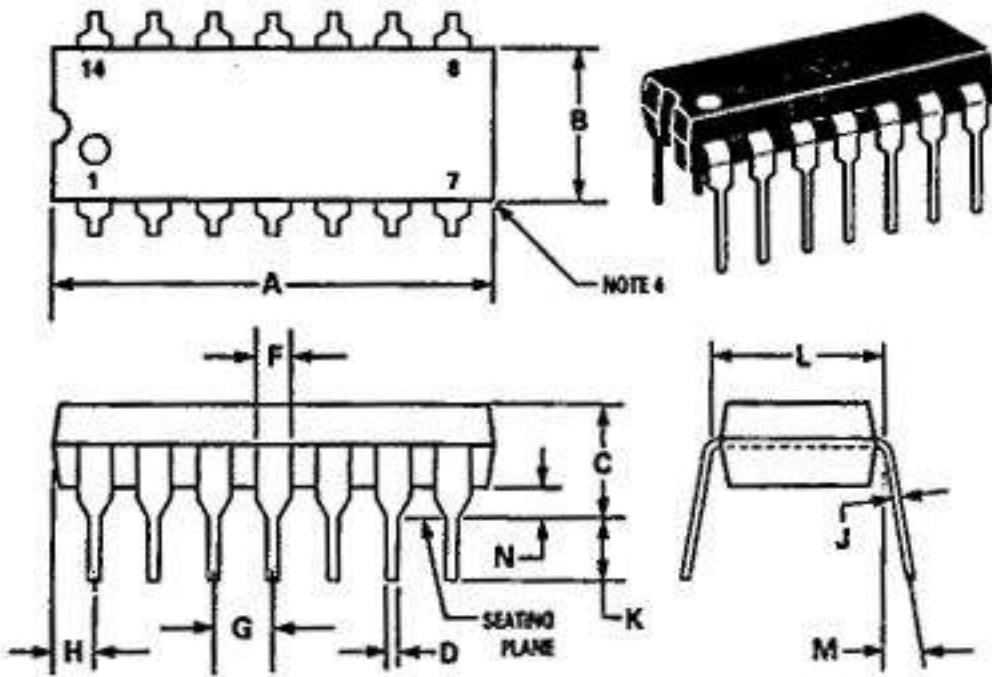

**N, P SUFFIX
PLASTIC PACKAGE
CASE 648-08**

$R_{\theta JA} = 100^{\circ}\text{C/W (TYP)}$

DIM	MILLIMETERS		INCHES	
	MIN	MAX	MIN	MAX
A	18.80	19.55	0.740	0.770
B	6.35	6.85	0.250	0.270
C	3.69	4.44	0.145	0.175
D	0.39	0.53	0.015	0.021
F	1.02	1.77	0.040	0.070
G	2.54 BSC		0.100 BSC	
H	1.27 BSC		0.050 BSC	
J	0.21	0.38	0.008	0.015
K	2.80	3.30	0.110	0.130
L	7.50	7.74	0.295	0.305
M	0°	10°	0°	10°
S	0.51	1.01	0.020	0.040

- NOTES:
- DIMENSIONING AND TOLERANCING PER ANSI Y14.5M, 1982.
 - CONTROLLING DIMENSION: INCH.
 - DIMENSION "L" TO CENTER OF LEADS WHEN FORMED PARALLEL.
 - DIMENSION "B" DOES NOT INCLUDE MOLD FLASH.
 - ROUNDED CORNERS OPTIONAL.

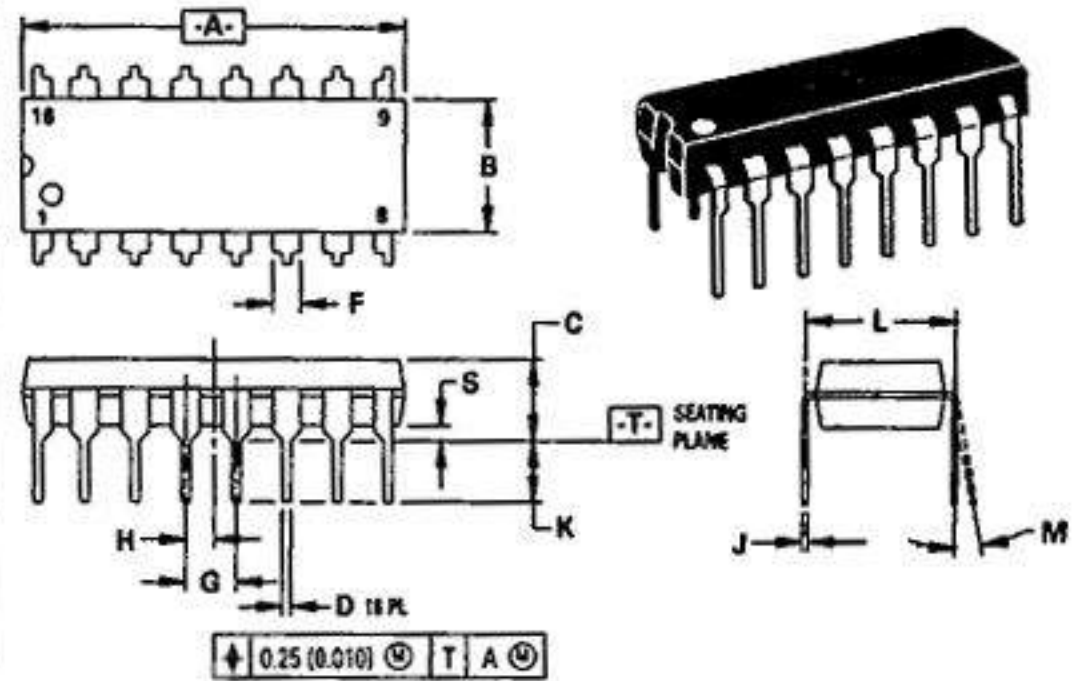

**P SUFFIX
PLASTIC PACKAGE
CASE 648C-02**

- NOTES:
- LEADS WITHIN 0.13 mm (0.005) RADIUS OF TRUE POSITION AT SEATING PLANE AT MAXIMUM MATERIAL CONDITION.
 - DIMENSION "L" TO CENTER OF LEADS WHEN FORMED PARALLEL.
 - DIMENSION "B" DOES NOT INCLUDE MOLD FLASH.
 - ROUNDED CORNERS OPTIONAL.
 - EXTERNAL LEAD CONNECTION, BETWEEN 4 AND 5, 12 AND 13 AS SHOWN.

DIM	MILLIMETERS		INCHES	
	MIN	MAX	MIN	MAX
A	18.80	21.34	0.740	0.840
B	6.10	6.60	0.240	0.260
C	3.69	4.69	0.145	0.185
D	0.38	0.53	0.015	0.021
F	1.02	1.78	0.040	0.070
G	2.54 BSC		0.100 BSC	
H	0.38	2.41	0.015	0.095
J	0.20	0.38	0.008	0.015
K	2.92	3.43	0.115	0.135
L	7.62 BSC		0.300 BSC	
M	0°	10°	0°	10°
N	0.39	1.01	0.015	0.040

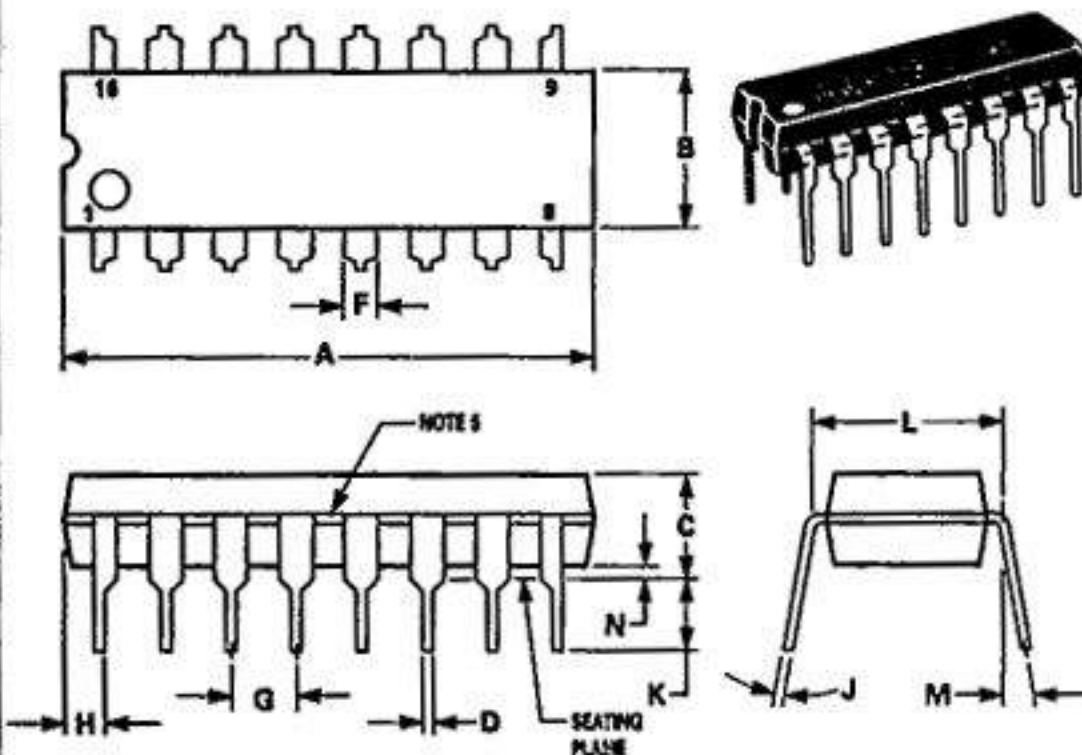

**J-8, J, JG, U, Z SUFFIX
CERAMIC PACKAGE
CASE 693-02**

$R_{\theta JA} = 100^{\circ}\text{C/W (TYP)}$

DIM	MILLIMETERS		INCHES	
	MIN	MAX	MIN	MAX
A	9.91	10.92	0.390	0.430
B	6.22	6.99	0.245	0.275
C	4.32	5.08	0.170	0.200
D	0.41	0.51	0.016	0.020
F	1.40	1.65	0.055	0.065
G	2.54 BSC		0.100 BSC	
H	1.14	1.65	0.045	0.065
J	0.20	0.30	0.008	0.012
K	3.18	4.06	0.125	0.160
L	7.37	7.87	0.290	0.310
M	—	15°	—	15°
N	0.51	1.02	0.020	0.040

- NOTES:
- LEADS WITHIN 0.13 mm (0.005) RAD OF TRUE POSITION AT SEATING PLANE AT MAXIMUM MATERIAL CONDITION.
 - DIMENSION "L" TO CENTER OF LEADS WHEN FORMED PARALLEL.

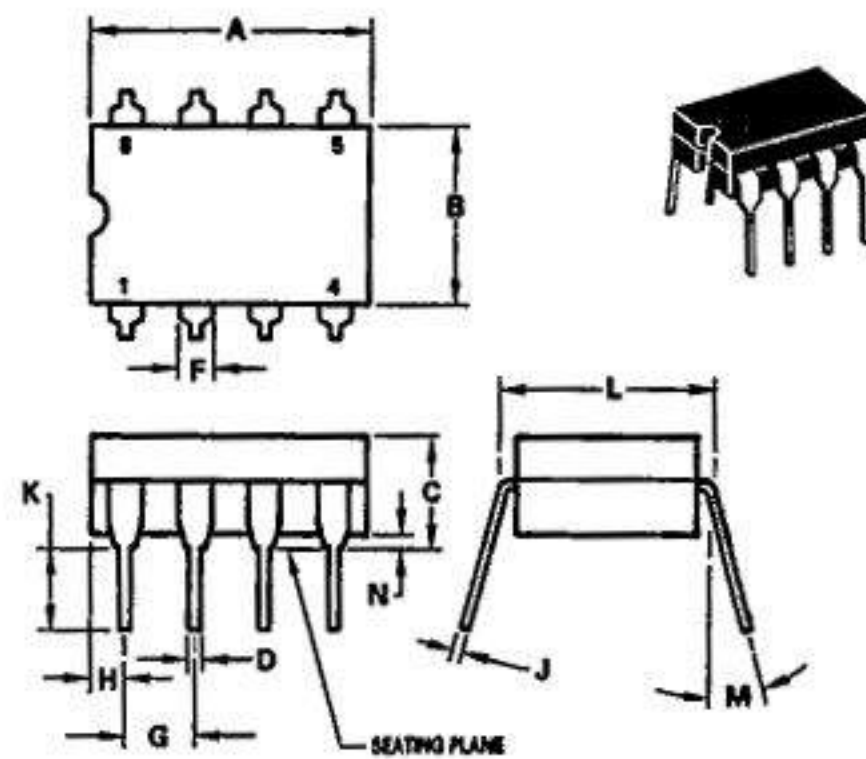

PACKAGE OUTLINE DIMENSIONS (continued)

**A, B, N, P SUFFIX
PLASTIC PACKAGE
CASE 707-02**
 $R_{\theta JA} = 100^{\circ}\text{C/W (TYP)}$

DIM	MILLIMETERS		INCHES	
	MIN	MAX	MIN	MAX
A	22.22	23.24	0.875	0.915
B	6.10	6.60	0.240	0.260
C	3.56	4.57	0.140	0.180
D	0.36	0.56	0.014	0.022
F	1.27	1.78	0.050	0.070
G	2.54 BSC		0.100 BSC	
H	1.02	1.52	0.040	0.060
J	0.20	0.30	0.008	0.012
K	2.92	3.43	0.115	0.136
L	7.62 BSC		0.300 BSC	
M	0°	15°	0°	15°
N	0.51	1.02	0.020	0.040



- NOTES:
1. POSITIONAL TOLERANCE OF LEADS (D), SHALL BE WITHIN 0.25mm(0.010) AT MAXIMUM MATERIAL CONDITION, IN RELATION TO SEATING PLANE AND EACH OTHER.
 2. DIMENSION L TO CENTER OF LEADS WHEN FORMED PARALLEL.
 3. DIMENSION B DOES NOT INCLUDE MOLD FLASH.

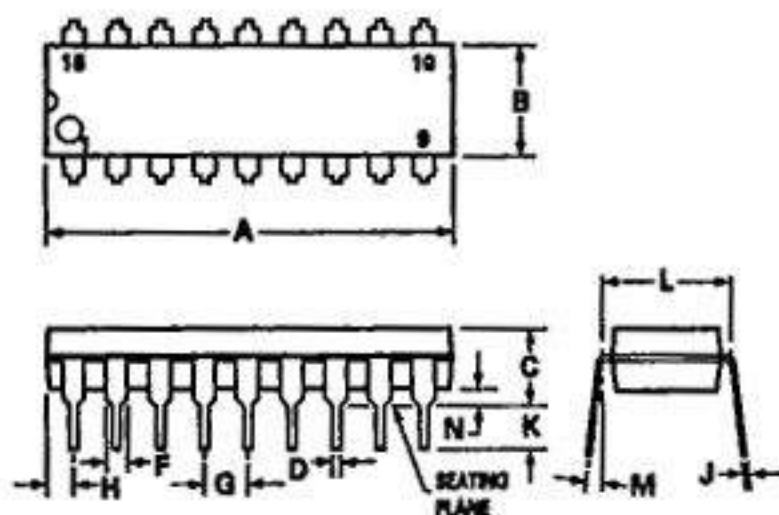

**J, L SUFFIX
CERAMIC PACKAGE
CASE 726-04**
 $R_{\theta JA} = 100^{\circ}\text{C/W (TYP)}$

DIM	MILLIMETERS		INCHES	
	MIN	MAX	MIN	MAX
A	22.35	23.11	0.880	0.910
B	6.10	7.43	0.240	0.296
C	—	5.08	—	0.200
D	0.38	0.53	0.015	0.021
F	1.40	1.78	0.055	0.070
G	2.54 BSC		0.100 BSC	
H	0.51	1.14	0.020	0.045
J	0.20	0.30	0.008	0.012
K	3.18	4.32	0.125	0.170
L	7.62 BSC		0.300 BSC	
M	0°	15°	0°	15°
N	0.51	1.02	0.020	0.040



- NOTES:
1. LEADS, TRUE POSITIONED WITHIN 0.25 mm (0.010) DIA. AT SEATING PLANE, AT MAXIMUM MATERIAL CONDITION.
 2. DIM "L" TO CENTER OF LEADS WHEN FORMED PARALLEL.
 3. DIM "A" & "B" INCLUDES MENISCUS.
 4. "F" DIMENSION IS FOR FULL LEADS. "HALF" LEADS ARE OPTIONAL AT LEAD POSITIONS 1, 9, 10, AND 18.

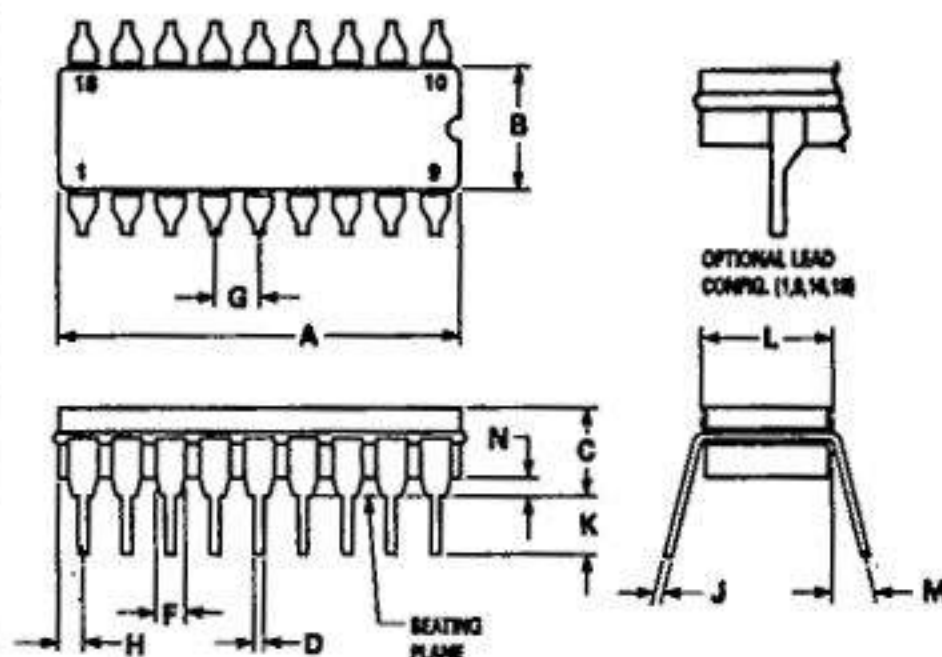

**D SUFFIX
CASE 751-03
PLASTIC PACKAGE
SO-8, SOP-8**
 $R_{\theta JA} = 190^{\circ}\text{C/W (SO-8)}$
 $R_{\theta JA} = 160^{\circ}\text{C/W (SOP-8)}$

DIM	MILLIMETERS		INCHES	
	MIN	MAX	MIN	MAX
A	4.80	5.00	0.189	0.196
B	3.80	4.00	0.150	0.157
C	1.35	1.75	0.054	0.068
D	0.35	0.49	0.014	0.019
F	0.40	1.25	0.016	0.049
G	1.27 BSC		0.050 BSC	
J	0.19	0.25	0.008	0.009
K	0.10	0.25	0.004	0.009
M	0°	7°	0°	7°
P	5.80	6.20	0.229	0.244
R	0.25	0.50	0.010	0.019



- NOTES:
1. DIMENSIONS A AND B ARE DATUMS AND T IS A DATUM SURFACE.
 2. POSITIONAL TOLERANCE FOR D DIMENSION (8 PLACES):
 $\pm 0.25 (0.010) \text{ (M) T B (A)}$
 3. POSITIONAL TOLERANCE FOR P DIMENSION (4 PLACES):
 $\pm 0.25 (0.010) \text{ (M) B (A)}$
 4. DIMENSIONING AND TOLERANCING PER ANSI Y14.5M, 1982.
 5. CONTROLLING DIMENSION: MILLIMETER.
 6. DIMENSION A AND B DO NOT INCLUDE MOLD PROTRUSION.
 7. MAXIMUM MOLD PROTRUSION 0.15 (0.006) PER SIDE.

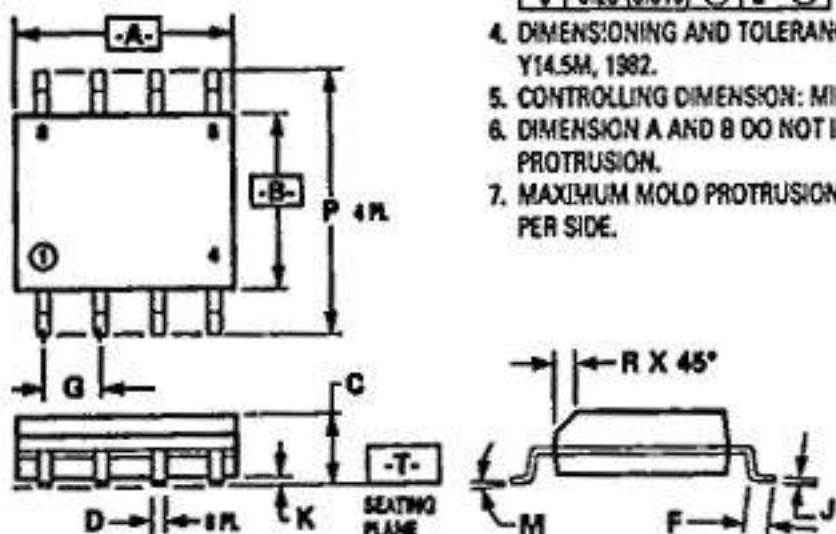

**D SUFFIX
PLASTIC PACKAGE
CASE 751A-02
SO-14**
 $R_{\theta JA} = 145^{\circ}\text{C/W (TYP)}$

DIM	MILLIMETERS		INCHES	
	MIN	MAX	MIN	MAX
A	8.56	8.75	0.337	0.344
B	3.80	4.00	0.150	0.157
C	1.35	1.75	0.054	0.068
D	0.35	0.49	0.014	0.019
F	0.40	1.25	0.016	0.049
G	1.27 BSC		0.050 BSC	
J	0.19	0.25	0.008	0.009
K	0.10	0.25	0.004	0.009
M	0°	7°	0°	7°
P	5.80	6.20	0.229	0.244
R	0.25	0.50	0.010	0.019



- NOTES:
1. DIMENSIONS A AND B ARE DATUMS AND T IS A DATUM SURFACE.
 2. POSITIONAL TOLERANCE FOR D DIMENSION (14 PLACES):
 $\pm 0.25 (0.010) \text{ (M) T B (A)}$
 3. POSITIONAL TOLERANCE FOR P DIMENSION (7 PLACES):
 $\pm 0.25 (0.010) \text{ (M) B (A)}$
 4. DIMENSIONING AND TOLERANCING PER ANSI Y14.5M, 1982.
 5. CONTROLLING DIMENSION: MILLIMETER.
 6. DIMENSION A AND B DO NOT INCLUDE MOLD PROTRUSION.
 7. MAXIMUM MOLD PROTRUSION 0.15 (0.006) PER SIDE.

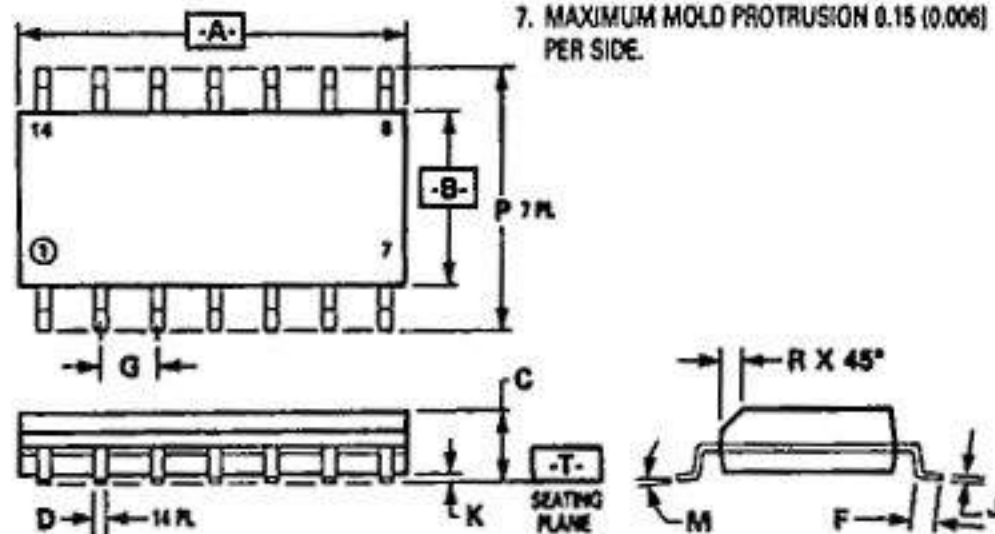

**DW SUFFIX
PLASTIC PACKAGE
CASE 751G-01
SO-16L**

DIM	MILLIMETERS		INCHES	
	MIN	MAX	MIN	MAX
A	10.15	10.45	0.400	0.411
B	7.40	7.60	0.292	0.299
C	2.35	2.65	0.093	0.104
D	0.35	0.49	0.014	0.019
F	0.50	0.90	0.020	0.035
G	1.27 BSC		0.050 BSC	
J	0.25	0.32	0.010	0.012
K	0.10	0.25	0.004	0.009
M	0°	7°	0°	7°
P	10.05	10.55	0.395	0.415
	0.25	0.75	0.010	0.029

- NOTES:
1. DIMENSIONS A AND B ARE DATUMS AND T IS A DATUM SURFACE.
 2. DIMENSIONING AND TOLERANCING PER ANSI Y14.5M, 1982.
 3. CONTROLLING DIMENSION: MILLIMETER.
 4. DIMENSION A AND B DO NOT INCLUDE MOLD PROTRUSION.
 5. MAXIMUM MOLD PROTRUSION 0.15 (0.006) PER SIDE.

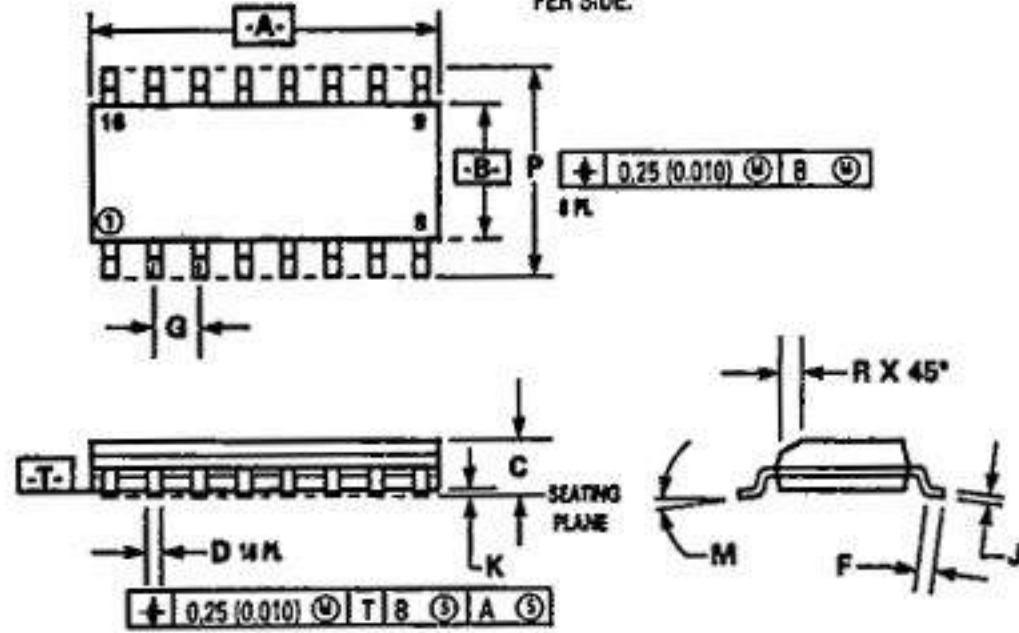

**CASE 762-01
PLASTIC MEDIUM
POWER PACKAGE
SIP-9**

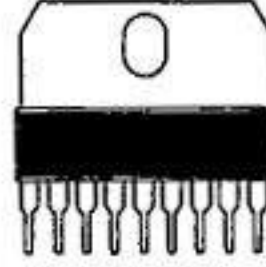

DIM	MILLIMETERS		INCHES	
	MIN	MAX	MIN	MAX
A	22.40	23.00	0.873	0.907
B	6.40	6.80	0.252	0.269
C	3.45	3.95	0.135	0.154
D	0.40	0.56	0.015	0.021
E	9.35	9.90	0.368	0.377
F	1.40	1.80	0.055	0.072
G	2.54 BSC		0.100 BSC	
H	1.51	1.71	0.059	0.067
J	0.380	0.400	0.014	0.015
K	3.95	4.30	0.155	0.169
M	30° BSC		30° BSC	
N	2.50	2.70	0.099	0.106
Q	3.15	3.45	0.124	0.135
R	13.80	13.90	0.543	0.547
S	1.65	1.95	0.064	0.076
U	22.00	22.20	0.866	0.874
V	0.55	0.75	0.021	0.029
W	2.89 BSC		0.113 BSC	
X	0.95	0.75	0.025	0.029
Y	2.70	2.80	0.106	0.110

- NOTES:
1. DIMENSIONS A, AND C ARE DATUMS, AND -T- IS A DATUM PLANE.
 2. POSITIONAL TOLERANCE FOR LEAD DIMENSION D:
 $\pm 0.25 (0.010) \text{ (M) } \cdot T, A \text{ (M)}$
 3. POSITIONAL TOLERANCE FOR LEAD DIMENSION J:
 $\pm 0.25 (0.010) \text{ (M) } \cdot T, C \text{ (M)}$
 4. POSITIONAL TOLERANCE FOR LEAD DIMENSION Q:
 $\pm 0.25 (0.010) \text{ (M) } \cdot T, A \text{ (M)}$
 5. DIMENSIONING AND TOLERANCING PER ANSI Y14.5, 1982.
 6. CONTROLLING DIMENSION: MILLIMETER.

